



# Negative Declaration & Notice Of Determination

SAN LUIS OBISPO COUNTY DEPARTMENT OF PLANNING AND BUILDING  
976 OSOS STREET • ROOM 200 • SAN LUIS OBISPO • CALIFORNIA 93408 • (805) 781-5600

**ENVIRONMENTAL DETERMINATION NO.** ED19-099

**DATE:** April 22, 2019

**PROJECT/ENTITLEMENT:** Labriola Grading Permit PMTG2018-00094

**APPLICANT NAME:** Michael Labriola **Email:** mike@tigrisnet.net  
**ADDRESS:** 2425 Golden Hill Road #106-121 Paso Robles, CA 93446  
**CONTACT PERSON:** Raymond Tran (Agent) **Telephone:** (626)235-5457

**PROPOSED USES/INTENT:** A request by Michael Labriola to grade for a two-story 7,713-square-foot single-family residence with an attached 3-car garage, 400-foot driveway, and septic system, which will result in the disturbance of approximately 1.66 acres of a 36.95 acre parcel and 2,875 cubic yards of cut and 2,233 cubic yards of fill. The proposed project is within the Agricultural land use category.

**LOCATION:** The project is located at 7005 Airport Road approximately 1 mile north of the City of Paso Robles. The site is in the Salinas River Sub Area, in the North County Planning Area.

**LEAD AGENCY:** County of San Luis Obispo  
Dept of Planning & Building  
976 Osos Street, Rm. 200  
San Luis Obispo, CA 93408-2040  
Website: <http://www.sloplanning.org>

**STATE CLEARINGHOUSE REVIEW:** YES  NO

**OTHER POTENTIAL PERMITTING AGENCIES:** None

**ADDITIONAL INFORMATION:** Additional information pertaining to this Environmental Determination may be obtained by contacting the above Lead Agency address or (805)781-5600.

**COUNTY "REQUEST FOR REVIEW" PERIOD ENDS AT ..... 4:30 p.m. (2 wks from above DATE)**

**30-DAY PUBLIC REVIEW PERIOD begins at the time of public notification**

## Notice of Determination

**State Clearinghouse No.** \_\_\_\_\_

This is to advise that the San Luis Obispo County \_\_\_\_\_ as  *Lead Agency*  
 *Responsible Agency* approved/denied the above described project on \_\_\_\_\_, and has made the following determinations regarding the above described project:

The project will not have a significant effect on the environment. A Negative Declaration was prepared for this project pursuant to the provisions of CEQA. Mitigation measures and monitoring were made a condition of approval of the project. A Statement of Overriding Considerations was not adopted for this project. Findings were made pursuant to the provisions of CEQA.

This is to certify that the Negative Declaration with comments and responses and record of project approval is available to the General Public at the 'Lead Agency' address above.

Katie Nall (kinall@co.slo.ca.us)

County of San Luis Obispo

**Signature**

**Project Manager Name**

**Date**

**Public Agency**



# Initial Study Summary – Environmental Checklist

SAN LUIS OBISPO COUNTY DEPARTMENT OF PLANNING AND BUILDING  
976 OSOS STREET • ROOM 200 • SAN LUIS OBISPO • CALIFORNIA 93408 • (805) 781-5600

(ver 5.10) [Usma Form](#)

## Project Title & No. Labriola Grading Permit ED19-097 (PMTG2018-00084)

**ENVIRONMENTAL FACTORS POTENTIALLY AFFECTED:** The proposed project could have a "Potentially Significant Impact" for at least one of the environmental factors checked below. Please refer to the attached pages for discussion on mitigation measures or project revisions to either reduce these impacts to less than significant levels or require further study.

<input checked="" type="checkbox"/> Aesthetics	<input type="checkbox"/> Geology and Soils	<input type="checkbox"/> Recreation
<input type="checkbox"/> Agricultural Resources	<input type="checkbox"/> Hazards/Hazardous Materials	<input type="checkbox"/> Transportation/Circulation
<input type="checkbox"/> Air Quality	<input type="checkbox"/> Noise	<input type="checkbox"/> Wastewater
<input checked="" type="checkbox"/> Biological Resources	<input type="checkbox"/> Population/Housing	<input type="checkbox"/> Water /Hydrology
<input type="checkbox"/> Cultural Resources	<input type="checkbox"/> Public Services/Utilities	<input type="checkbox"/> Land Use

### DETERMINATION: (To be completed by the Lead Agency)

On the basis of this initial evaluation, the Environmental Coordinator finds that:

- The proposed project COULD NOT have a significant effect on the environment, and a NEGATIVE DECLARATION will be prepared.
- Although the proposed project could have a significant effect on the environment, there will not be a significant effect in this case because revisions in the project have been made by or agreed to by the project proponent. A MITIGATED NEGATIVE DECLARATION will be prepared.
- The proposed project MAY have a significant effect on the environment, and an ENVIRONMENTAL IMPACT REPORT is required.
- The proposed project MAY have a "potentially significant impact" or "potentially significant unless mitigated" impact on the environment, but at least one effect 1) has been adequately analyzed in an earlier document pursuant to applicable legal standards, and 2) has been addressed by mitigation measures based on the earlier analysis as described on attached sheets. An ENVIRONMENTAL IMPACT REPORT is required, but it must analyze only the effects that remain to be addressed.
- Although the proposed project could have a significant effect on the environment, because all potentially significant effects (a) have been analyzed adequately in an earlier EIR or NEGATIVE DECLARATION pursuant to applicable standards, and (b) have been avoided or mitigated pursuant to that earlier EIR or NEGATIVE DECLARATION, including revisions or mitigation measures that are imposed upon the proposed project, nothing further is required.

Katie Nall ([kinall@co.slo.ca.us](mailto:kinall@co.slo.ca.us))

Prepared by (Print)

Signature

4/16/2019

Date

Holly Phipps

Reviewed by (Print)

Signature

4/16/2019

Date



**Project Environmental Analysis**

The County's environmental review process incorporates all of the requirements for completing the Initial Study as required by the California Environmental Quality Act (CEQA) and the CEQA Guidelines. The Initial Study includes staff's on-site inspection of the project site and surroundings and a detailed review of the information in the file for the project. In addition, available background information is reviewed for each project. Relevant information regarding soil types and characteristics, geologic information, significant vegetation and/or wildlife resources, water availability, wastewater disposal services, existing land uses and surrounding land use categories and other information relevant to the environmental review process are evaluated for each project. Exhibit A includes the references used, as well as the agencies or groups that were contacted as a part of the Initial Study. The County Planning Department uses the checklist to summarize the results of the research accomplished during the initial environmental review of the project.

Persons, agencies or organizations interested in obtaining more information regarding the environmental review process for a project should contact the County of San Luis Obispo Planning Department, 976 Osos Street, Rm. 200, San Luis Obispo, CA, 93408-2040 or call (805) 781-5600.

**A. PROJECT**

**DESCRIPTION:** Request by Michael Labriola to grade for a two-story 7,713-square-foot single-family residence with an attached 3-car garage, 400-foot driveway, and septic system, which will result in the disturbance of approximately 1.66 acres of a 36.95 acre parcel and 2,875 cubic yards of cut and 2,233 cubic yards of fill. The proposed project is within the Agricultural land use category and is located at 7005 Airport Road approximately 1 mile north of the City of Paso Robles. The site is in the Salinas River Sub Area, in the North County Planning Area.

**ASSESSOR PARCEL NUMBER(S):** 027-191-071

Latitude: 35 degrees 42' 15.1" N Longitude: 120 degrees 38 ' 38.3 " W **SUPERVISORIAL DISTRICT # 1**

**B. EXISTING SETTING**

**PLAN AREA:** North County      **SUB:** Salinas River      **COMM:** Rural

**LAND USE CATEGORY:** Agriculture

**COMB. DESIGNATION:** Airport Review

**PARCEL SIZE:** 36.95 acres

**TOPOGRAPHY:** Nearly level

**VEGETATION:** Shrubs

**EXISTING USES:** Single-Family Residence

**SURROUNDING LAND USE CATEGORIES AND USES:**

<i>North:</i> Agriculture / residence	<i>East:</i> Agriculture / agricultural uses, residence
<i>South:</i> Agriculture / agricultural uses, residence	<i>West:</i> Agriculture / vacant

## C. ENVIRONMENTAL ANALYSIS

During the Initial Study process, at least one issue was identified as having a potentially significant environmental effects (see following Initial Study). Those potentially significant items associated with the proposed uses can be minimized to less than significant levels.



## COUNTY OF SAN LUIS OBISPO INITIAL STUDY CHECKLIST

1. AESTHETICS	Potentially Significant	Impact can & will be mitigated	Insignificant Impact	Not Applicable
<i>Will the project:</i>				
a) Create an aesthetically incompatible site open to public view?	<input type="checkbox"/>	<input type="checkbox"/>	<input checked="" type="checkbox"/>	<input type="checkbox"/>
b) Introduce a use within a scenic view open to public view?	<input type="checkbox"/>	<input type="checkbox"/>	<input checked="" type="checkbox"/>	<input type="checkbox"/>
c) Change the visual character of an area?	<input type="checkbox"/>	<input type="checkbox"/>	<input checked="" type="checkbox"/>	<input type="checkbox"/>
d) Create glare or night lighting, which may affect surrounding areas?	<input type="checkbox"/>	<input checked="" type="checkbox"/>	<input checked="" type="checkbox"/>	<input type="checkbox"/>
e) Impact unique geological or physical features?	<input type="checkbox"/>	<input type="checkbox"/>	<input checked="" type="checkbox"/>	<input type="checkbox"/>
f) Other: _____	<input type="checkbox"/>	<input type="checkbox"/>	<input type="checkbox"/>	<input checked="" type="checkbox"/>

### Aesthetics

**Setting.** The proposed project is located immediately west of and adjacent to the city limits of the City of Paso Robles, within a predominately agricultural area. The visual setting of the area is characterized by large agricultural parcels with scattered oak trees and vineyards. Structural components in the area are composed of primarily scattered single family residences, wine processing facilities, and agricultural accessory buildings. Topography generally alternates between gently rolling hills and generally flat spans. The proposed project site vegetation is currently composed of shrubs.

**Impact.** Future development of a two-story single-family residence with an attached three-car garage would be visible from Airport Road. The project could be intermittently seen from Airport Road, a collector road. Section 22.10.090.(c)2.(b)1 provides an exception to the maximum allowable height standard by permitting additional height (to a maximum of 45 feet) provided that the required side, and rear setbacks shall be increased one foot in width for each foot of height over 35 feet. The proposed side and rear setbacks accommodate this exception, therefore, the proposed allowable maximum building height is 40 feet above the average natural grade. The project is not located within a highway design corridor or City scenic roadways.

Airport Road moves perpendicular to the line of sight toward the building site, which is filtered through hills and vegetation. The project site is located approximately 1,000 feet west of Airport Road. This





distance along with the brief views of the project site, filtered through hills and vegetation decreases the visual impacts. The project is visible for an extended duration of travel on any roadway. Future development of the proposed single-family residence would not significantly change the visual character of the area. However, exterior lighting may create lighting and glare when viewed intermittently from Airport Road.

Nighttime lighting for the project has the potential to be visually intrusive in the landscape and be a source of nighttime glare.

**Mitigation/Conclusion.** The applicant shall submit an exterior lighting plan showing the location, height, and intensity of proposed exterior lighting. Lighting shall be shielded and downward facing to reduce the glare. Compliance with the County’s exterior lighting ordinance Section 22.10.060 will reduce the lighting and glare impact to less than significant.

To ensure compatibility with the surrounding environment, the applicant has agreed to submit a final color and materials board for review and approval. Exterior colors and materials shall be consistent with County guidelines. Based on implementation of these measures, potential visual impacts would be less than significant.

<b>2. AGRICULTURAL RESOURCES</b> <i>Will the project:</i>	<b>Potentially Significant</b>	<b>Impact can &amp; will be mitigated</b>	<b>Insignificant Impact</b>	<b>Not Applicable</b>
a) <i>Convert prime agricultural land, per NRCS soil classification, to non-agricultural use?</i>	<input type="checkbox"/>	<input type="checkbox"/>	<input checked="" type="checkbox"/>	<input type="checkbox"/>
b) <i>Convert Prime Farmland, Unique Farmland, or Farmland of Statewide Importance to non-agricultural use?</i>	<input type="checkbox"/>	<input type="checkbox"/>	<input checked="" type="checkbox"/>	<input type="checkbox"/>
c) <i>Impair agricultural use of other property or result in conversion to other uses?</i>	<input type="checkbox"/>	<input type="checkbox"/>	<input checked="" type="checkbox"/>	<input type="checkbox"/>
d) <i>Conflict with existing zoning for agricultural use, or Williamson Act program?</i>	<input type="checkbox"/>	<input type="checkbox"/>	<input checked="" type="checkbox"/>	<input type="checkbox"/>
e) <i>Other:</i> _____	<input type="checkbox"/>	<input type="checkbox"/>	<input type="checkbox"/>	<input checked="" type="checkbox"/>

**Agricultural Resources**

**Setting.** Project Elements. The following area-specific elements relate to the property’s importance for agricultural production:

Land Use Category: Agriculture

Historic/Existing Commercial Crops: None

State Classification: Not Prime Farmland, Farmland of Statewide Importance

In Agricultural Preserve? Yes – Estrella AG Preserve Area

Under Williamson Act contract? No

The soil type(s) and characteristics on the subject property include:

Arbuckle-Positas complex (15 - 30 % slope).

Arbuckle. This moderately to steeply sloping coarse loamy soil is considered moderately drained. The soil has moderate erodibility and low shrink-swell characteristics, as well as having potential septic system constraints due to: steep slopes, slow percolation. The soil is considered Class IV without irrigation and Class IV when irrigated.

Arbuckle-San Ysidro complex (2 - 9% slope).

Arbuckle. This gently sloping coarse loamy soil is considered moderately drained. The soil has moderate erodibility and low shrink-swell characteristics, as well as having potential septic system constraints due to: slow percolation. The soil is considered Class IV without irrigation and Class II when irrigated.

**Impact.** The proposed project will be located on a portion of the property that will be closest to access roads, so that development does not diminish the utility of farm fields. No significant impacts to agriculture resources are anticipated.

**Mitigation/Conclusion.** No mitigation measures are necessary.

### 3. AIR QUALITY

*Will the project:*

	Potentially Significant	Impact can & will be mitigated	Insignificant Impact	Not Applicable
a) <i>Violate any state or federal ambient air quality standard, or exceed air quality emission thresholds as established by County Air Pollution Control District?</i>	<input type="checkbox"/>	<input type="checkbox"/>	<input checked="" type="checkbox"/>	<input type="checkbox"/>
b) <i>Expose any sensitive receptor to substantial air pollutant concentrations?</i>	<input type="checkbox"/>	<input type="checkbox"/>	<input checked="" type="checkbox"/>	<input type="checkbox"/>
c) <i>Create or subject individuals to objectionable odors?</i>	<input type="checkbox"/>	<input type="checkbox"/>	<input checked="" type="checkbox"/>	<input type="checkbox"/>
d) <i>Be inconsistent with the District's Clean Air Plan?</i>	<input type="checkbox"/>	<input type="checkbox"/>	<input checked="" type="checkbox"/>	<input type="checkbox"/>
e) <i>Result in a cumulatively considerable net increase of any criteria pollutant either considered in non-attainment under applicable state or federal ambient air quality standards that are due to increased energy use or traffic generation, or intensified land use change?</i>	<input type="checkbox"/>	<input type="checkbox"/>	<input checked="" type="checkbox"/>	<input type="checkbox"/>

### GREENHOUSE GASES

f) <i>Generate greenhouse gas emissions, either directly or indirectly, that may have a significant impact on the environment?</i>	<input type="checkbox"/>	<input type="checkbox"/>	<input checked="" type="checkbox"/>	<input type="checkbox"/>
--	--------------------------	--------------------------	-------------------------------------	--------------------------

### 3. AIR QUALITY

*Will the project:*

	Potentially Significant	Impact can & will be mitigated	Insignificant Impact	Not Applicable
g) <i>Conflict with an applicable plan, policy or regulation adopted for the purpose of reducing the emissions of greenhouse gases?</i>	<input type="checkbox"/>	<input type="checkbox"/>	<input checked="" type="checkbox"/>	<input type="checkbox"/>
h) <i>Other:</i> _____	<input type="checkbox"/>	<input type="checkbox"/>	<input type="checkbox"/>	<input checked="" type="checkbox"/>

#### Air Quality

**Setting.** The project proposes to disturb soils that have been given a wind erodibility rating of 3, which is considered “moderate”.

The Air Pollution Control District (APCD) has developed and updated their CEQA Air Quality Handbook (2012) to evaluate project specific impacts and help determine if air quality mitigation measures are needed, or if potentially significant impacts could result. To evaluate long-term emissions, cumulative effects, and establish countywide programs to reach acceptable air quality levels, a Clean Air Plan has been adopted (prepared by APCD).

**Greenhouse Gas (GHG) Emissions** are said to result in an increase in the earth’s average surface temperature. This is commonly referred to as global warming. The rise in global temperature is associated with long-term changes in precipitation, temperature, wind patterns, and other elements of the earth’s climate system. This is also known as climate change. These changes are now thought to be broadly attributed to GHG emissions, particularly those emissions that result from the human production and use of fossil fuels.

The passage of AB32, the California Global Warming Solutions Act (2006), recognized the need to reduce GHG emissions and set the greenhouse gas emissions reduction goal for the State of California into law. The law required that by 2020, State emissions must be reduced to 1990 levels. This is to be accomplished by reducing greenhouse gas emissions from significant sources via regulation, market mechanisms, and other actions. Subsequent legislation (e.g., SB97-Greenhouse Gas Emissions bill) directed the California Air Resources Board (CARB) to develop statewide thresholds.

In March 2012, the San Luis Obispo County Air Pollution Control District (APCD) approved thresholds for GHG emission impacts, and these thresholds have been incorporated the APCD’s CEQA Air Quality Handbook. APCD determined that a tiered process for residential / commercial land use projects was the most appropriate and effective approach for assessing the GHG emission impacts. The tiered approach includes three methods, any of which can be used for any given project:

1. Qualitative GHG Reduction Strategies (e.g. Climate Action Plans): A qualitative threshold that is consistent with AB 32 Scoping Plan measures and goals; or,
2. Bright-Line Threshold: Numerical value to determine the significance of a project’s annual GHG emissions; or,
3. Efficiency-Based Threshold: Assesses the GHG impacts of a project on an emissions per capita basis.

For most projects the Bright-Line Threshold of 1,150 Metric Tons CO<sub>2</sub>/year (MT CO<sub>2</sub>e/yr) will be the most applicable threshold. In addition to the residential/commercial threshold options proposed above, a bright-line numerical value threshold of 10,000 MT CO<sub>2</sub>e/yr was adopted for stationary source (industrial) projects.

It should be noted that projects that generate less than the above mentioned thresholds will also participate in emission reductions because air emissions, including GHGs, are under the purview of the California Air Resources Board (or other regulatory agencies) and will be “regulated” either by CARB, the Federal Government, or other entities. For example, new vehicles will be subject to increased fuel economy standards and emission reductions, large and small appliances will be subject to more strict emissions standards, and energy delivered to consumers will increasingly come from renewable sources. Other programs that are intended to reduce the overall GHG emissions include Low Carbon Fuel Standards, Renewable Portfolio standards and the Clean Car standards. As a result, even the emissions that result from projects that produce fewer emissions than the threshold will be subject to emission reductions.

Under CEQA, an individual project’s GHG emissions will generally not result in direct significant impacts. This is because the climate change issue is global in nature. However, an individual project could be found to contribute to a potentially significant cumulative impact. Projects that have GHG emissions above the noted thresholds may be considered cumulatively considerable and require mitigation.

**Impact.** As proposed, the project will result in the disturbance of approximately 72,310 square-feet (1.66 acres). This will result in the creation of construction dust, as well as short- and long-term vehicle emissions. However, the project would be moving less than 1,200 cubic yards/day of material and would require less than four acres of grading. The project is also not in close proximity to sensitive receptors that might otherwise result in nuisance complaints and be subject to limited dust and/or emission control measures during construction. Due to the distance of any known fault (at least three miles away) or serpentine rock outcrop (at least three miles away), it is not expected that any naturally occurring asbestos would be encountered during any earthmoving activities. From an operational standpoint, based on Table 1-1 of the CEQA Air Quality Handbook (2012), the project will not exceed operational thresholds triggering mitigation.

The project is consistent with the general level of development anticipated and projected in the Clean Air Plan. Using the GHG threshold information described in the Setting section, the project is expected to generate less than the Bright-Line Threshold of 1,150 metric tons of GHG emissions. Therefore, the project’s potential direct and cumulative GHG emissions are found to be less significant and less than a cumulatively considerable contribution to GHG emissions. Section 15064(h)(2) of the CEQA Guidelines provide guidance on how to evaluate cumulative impacts. If it is shown that an incremental contribution to a cumulative impact, such as global climate change, is not ‘cumulatively considerable’, no mitigation is required. Because this project’s emissions fall under the threshold, no mitigation is required.

**Mitigation/Conclusion.** The project would result in limited short-term air quality impacts that would be minimized through compliance with County Land Use Ordinance requirements. Therefore, potential impacts on Air Quality and GHG emissions would be less than significant.

<b>4. BIOLOGICAL RESOURCES</b> <i>Will the project:</i>	Potentially Significant	Impact can & will be mitigated	Insignificant Impact	Not Applicable
<b>a) Result in a loss of unique or special status species* or their habitats?</b>	<input type="checkbox"/>	<input checked="" type="checkbox"/>	<input type="checkbox"/>	<input type="checkbox"/>
<b>b) Reduce the extent, diversity or quality of native or other important vegetation?</b>	<input type="checkbox"/>	<input type="checkbox"/>	<input checked="" type="checkbox"/>	<input type="checkbox"/>
<b>c) Impact wetland or riparian habitat?</b>	<input type="checkbox"/>	<input type="checkbox"/>	<input checked="" type="checkbox"/>	<input type="checkbox"/>



#### 4. BIOLOGICAL RESOURCES

*Will the project:*

	Potentially Significant	Impact can & will be mitigated	Insignificant Impact	Not Applicable
d) <i>Interfere with the movement of resident or migratory fish or wildlife species, or factors, which could hinder the normal activities of wildlife?</i>	<input type="checkbox"/>	<input checked="" type="checkbox"/>	<input type="checkbox"/>	<input type="checkbox"/>
e) <i>Conflict with any regional plans or policies to protect sensitive species, or regulations of the California Department of Fish &amp; Wildlife or U.S. Fish &amp; Wildlife Service?</i>	<input type="checkbox"/>	<input type="checkbox"/>	<input checked="" type="checkbox"/>	<input type="checkbox"/>
f) <i>Other:</i> _____	<input type="checkbox"/>	<input type="checkbox"/>	<input type="checkbox"/>	<input checked="" type="checkbox"/>

\* Species – as defined in Section 15380 of the CEQA Guidelines, which includes all plant and wildlife species that fall under the category of rare, threatened or endangered, as described in this section.

#### Biological Resources

**Setting.** The following are existing elements on or near the proposed project relating to potential biological concerns:

On-site Vegetation: grasses and shrubs

Name and distance from blue line creek(s): 3 unnamed intermittent ephemeral streams are onsite. One on the western edge of the property, one through the middle, and one on the eastern portion. Estrella River is located 0.5 miles to the north west of the site.

Habitat(s): San Joaquin Kit Fox Habitat

Natural Diversity Database identified the following sensitive species and sensitive plant communities as *potentially* occurring site:

#### Vegetation

Jared's pepper-grass (*Lepidium jaredii* ssp. *jaredii*) List 1B: Jared's pepper-grass (*Lepidium jaredii* ssp. *jaredii*) has been found about 0.78 miles to the east. This annual herb is found generally on alkaline-adobe soils in valley and foothill grassland areas at elevations between 335 and 1005 meters (1,100 to 3,300 feet). It has a blooming period of March-May. The CNPS considers this plant rare in California (List 1b, RED 3-2-3).

Oval-leaved snapdragon (*Antirrhinum ovatum*) List 4: Oval-leaved snapdragon (*Antirrhinum ovatum*) has been found about 0.78 miles to the east. This annual herb is generally found growing on alkaline clay or gypsum soils in chaparral, cismontane woodland, pinyon and juniper woodland, and valley and foothill grasslands at elevations between 200 and 1,000 meters (650 to 3,280 feet). It has a blooming period of May-November. Oval-leaved snapdragon is considered a plant of limited distribution by the CNPS (List 4, RED 1-1-3).

Santa Lucia dwarf rush (*Juncus luciensis*) List 1B: The potential for the Santa Lucia dwarf rush (*Juncus luciensis*) has been identified about 0.78 miles to the east. This annual herb is generally found growing in chaparral, great basin scrub, lower montane coniferous forest, meadows and seeps, and vernal pools at elevations between 300 and 2040 meters (1000 to 6690 feet). It is a California endemic and has a blooming period of April-July.

Four (4) biological reports were prepared for areas within 1 mile of the project site. Out of the 4 reports, only one discussed the potential for Jared's pepper-grass to occur on a site located 0.8 miles to the north. No report found the above discussed special status plant species. In addition, the soils on the project site do not support the sensitive species listed as potentially occurring within 1 mile.

## **Wildlife**

### **San Joaquin Kit Fox**

The California Natural Diversity Database identified this area as important habitat for the San Joaquin Kit Fox, a federally listed endangered species and a state listed threatened species. The kit fox is uncommon to rare. They reside in arid regions of the southern half of the state. A usually nocturnal mammal, kit fox live in annual grasslands or grassy open stages of vegetation dominated by scattered brush, shrubs, and scrub. Kit foxes primarily are carnivorous, subsisting on black-tailed jackrabbits and desert cottontails, rodents (especially kangaroo rats and ground squirrels), insects, reptiles, and some birds, bird eggs, and vegetation. Their cover is provided by dens they dig in open, level areas with loose-textured, sandy and loamy soils. Pups are born in these dens in February through April. Pups are weaned at about 4-5 months.

Potential predators are coyotes, large hawks and owls, eagles, and bobcats. Cultivation has eliminated much of the kit fox habitat in the project vicinity. Kit foxes are vulnerable to many human activities, such as hunting, use of rodenticides and other poisons, off-road vehicles, and trapping.

**Impact.** The project would result in 1.66 acres (73,309 square feet) of site disturbance; however, the project will result in the permanent site disturbance of 0.84 (36,590 square feet) acres of kit fox habitat. Mitigation has been identified to mitigate for the permanent loss of kit fox habitat per CDFW requirements.

With regards to the San Joaquin Kit Fox, based on the results of previous Kit Fox Habitat Evaluations that have been conducted for the Salinas River Sub area, the standard mitigation ratio for projects on parcels less than 40 acres in size has been established as 4:1. This means that all impacts to kit fox habitat must be mitigated at a ratio of 4 acres conserved for each acre impacted (4:1). The project will result in the permanent disturbance of 0.84 acres of kit fox habitat.

Applicants have the option of hiring a qualified biologist to conduct a Kit Fox Habitat Evaluation of the project site if the applicant believes that the evaluation would lower the score and reduce the required mitigation ratio. However, the applicant has chosen to accept the standard mitigation ratio of (4:1), which requires that a total compensatory acreage of 3.36 (0.84 acres multiplied by a 4:1 ratio) be mitigated.

It is determined the above discussed sensitive species will not be impacted do to the proposed project. At this time, there is no indication of habitat suitable for supporting special status plant species, therefore no mitigations are required.

**Mitigation/Conclusion.** With regards to the San Joaquin Kit Fox, the applicant will be required to mitigate the loss of 3.36 acres of kit fox habitat by one of the following ways:

- ✓ Deposit of funds to an approved in-lieu fee program;
- ✓ provide for the protection of kit foxes in perpetuity through acquisition of fee or conservation easement of suitable habitat in the kit fox corridor area; or
- ✓ purchase credits in an approved conservation bank.

To prevent inadvertent harm to kit fox, the applicant has agreed to retain a biologist for a pre-construction survey, a pre-construction briefing for contractors, and monitoring activities in addition to implementing cautionary construction measures. These mitigation measures are listed in detail in Exhibit B Mitigation Summary Table.



## 5. CULTURAL RESOURCES

*Will the project:*

	Potentially Significant	Impact can & will be mitigated	Insignificant Impact	Not Applicable
a) <i>Disturb archaeological resources?</i>	<input type="checkbox"/>	<input type="checkbox"/>	<input checked="" type="checkbox"/>	<input type="checkbox"/>
b) <i>Disturb historical resources?</i>	<input type="checkbox"/>	<input type="checkbox"/>	<input checked="" type="checkbox"/>	<input type="checkbox"/>
c) <i>Disturb paleontological resources?</i>	<input type="checkbox"/>	<input type="checkbox"/>	<input checked="" type="checkbox"/>	<input type="checkbox"/>
d) <i>Cause a substantial adverse change to a Tribal Cultural Resource?</i>	<input type="checkbox"/>	<input type="checkbox"/>	<input checked="" type="checkbox"/>	<input type="checkbox"/>
e) <i>Other:</i> _____	<input type="checkbox"/>	<input type="checkbox"/>	<input type="checkbox"/>	<input checked="" type="checkbox"/>

### Cultural Resources

**Setting.** The project is located in an area historically occupied by the Salinan/ Chumash . No historic structures are present and no paleontological resources are known to exist in the area.

One archaeological report was prepared within ¼ mile of the subject property. This report was for the entire El Pomar/Estrella Planning area and concluded in findings (Crawford, 1999). The report found out of the 133,000 acre area, only 21 recorded archaeological sites and five significant historical structures were found. While this number is low for the size, the report recommended areas denoted as moderately sensitive for archeological resources should be subject to archeological surveys prior to development. This area is not considered moderately sensitive for archeological resources. Per LUO Section 22.60.040(D), an archeological report (Phase 1) was determined unnecessary for the following reasons: no resources or indicative features are observed that may have attracted pre-historic activities; the potential for resources was determined to be very low; and the proposed site has been previously disturbed with road scars. Should any materials be unearthed during grading, LUO Section 22.10.040 requires that work must stop until the discovered resource is analyzed and adequately mitigated before work may continue.

In order to meet AB52 Cultural Resources requirements, outreach to four Native American tribal groups has been conducted (Northern Salinan, Xolon Salinan, Yak Tityu Tityu Northern Chumas, and the Northern Chumash Tribal Council). Comments were received from one of the tribal groups on April 16, 2019 with no concerns over the proposed project.

**Impact.** The project is not located in an area that would be considered culturally sensitive due to lack of physical features typically associated with prehistoric occupation. No evidence of cultural materials was noted on the property. Per AB52, tribal consultation was performed and no resources were identified. Impacts to historical or paleontological resources are not expected.

**Mitigation/Conclusion.** No significant cultural resource impacts are expected to occur. In the event of an unanticipated discovery of archeological resources during earth-moving activities, compliance with the Land Use Ordinance would ensure potential impacts would be reduced to less than significant. Therefore, no additional mitigation is necessary.

## 6. GEOLOGY AND SOILS

*Will the project:*

	Potentially Significant	Impact can & will be mitigated	Insignificant Impact	Not Applicable
a) <i>Result in exposure to or production of unstable earth conditions, such as landslides, earthquakes, liquefaction, ground failure, land subsidence or other similar hazards?</i>	<input type="checkbox"/>	<input type="checkbox"/>	<input checked="" type="checkbox"/>	<input type="checkbox"/>
b) <i>Be within a California Geological Survey "Alquist-Priolo" Earthquake Fault Zone", or other known fault zones*?</i>	<input type="checkbox"/>	<input type="checkbox"/>	<input checked="" type="checkbox"/>	<input type="checkbox"/>
c) <i>Result in soil erosion, topographic changes, loss of topsoil or unstable soil conditions from project-related improvements, such as vegetation removal, grading, excavation, or fill?</i>	<input type="checkbox"/>	<input type="checkbox"/>	<input checked="" type="checkbox"/>	<input type="checkbox"/>
d) <i>Include structures located on expansive soils?</i>	<input type="checkbox"/>	<input type="checkbox"/>	<input checked="" type="checkbox"/>	<input type="checkbox"/>
e) <i>Be inconsistent with the goals and policies of the County's Safety Element relating to Geologic and Seismic Hazards?</i>	<input type="checkbox"/>	<input type="checkbox"/>	<input checked="" type="checkbox"/>	<input type="checkbox"/>
f) <i>Preclude the future extraction of valuable mineral resources?</i>	<input type="checkbox"/>	<input type="checkbox"/>	<input checked="" type="checkbox"/>	<input type="checkbox"/>
g) <i>Other: _____</i>	<input type="checkbox"/>	<input type="checkbox"/>	<input type="checkbox"/>	<input checked="" type="checkbox"/>

\* Per Division of Mines and Geology Special Publication #42

**Setting.** The following relates to the project's geologic aspects or conditions:

Topography: Gently rolling

Within County's Geologic Study Area?: No

Landslide Risk Potential: Low to moderate

Liquefaction Potential: Low

Nearby potentially active faults?: No Distance? N/A

Area known to contain serpentine or ultramafic rock or soils?: No

Shrink/Swell potential of soil: Low

Other notable geologic features? None

**Impact.** The proposed project would result in the disturbance of approximately 1.66 acres of a 36.95 acre parcel, including a total of 2,875 cubic yards of cut and 2,233 cubic yards of fill. During grading activities, there is a potential for erosion and down-gradient sedimentation to occur. The applicant has included proposed grading and erosion control measures to be implemented during construction on



the project site. These measures include protection of slopes, stockpiles, disturbed areas, and access areas.

The proposed single-family residence is to be on a cut pad. The proposed driveway improvements consists of cut and fill slopes. The intensification of impervious surfaces on the project site will increase the volume and velocity of runoff generated by the site compared with existing conditions. Based on the NRCS soil survey, soils covering the project site exhibit moderate susceptibility for erosion. Erosion of graded areas and discharge of sediment down slope will likely result, if adequate temporary and permanent measures are not taken before, during and after vegetation removal and grading. Compliance with relevant provision of the Building Code and Land use Ordinance will address potential impacts to erosion.

A sedimentation and erosion control plan is required for all construction and grading projects (LUO Sec. 22.52.120) to minimize erosion impacts. When required, the plan is prepared by a civil engineer to address both temporary and long-term sedimentation and erosion impacts. The project will also be subject to Regional Water Quality Control Board requirements for a SWPPP to manage surface drainage and erosion during construction.

**Mitigation/Conclusion.** No additional mitigation measures above what is already required by ordinance are necessary.

**7. HAZARDS & HAZARDOUS MATERIALS - Will the project:**

	Potentially Significant	Impact can & will be mitigated	Insignificant Impact	Not Applicable
a) <i>Create a hazard to the public or the environment through the routine transport, use, or disposal of hazardous materials?</i>	<input type="checkbox"/>	<input type="checkbox"/>	<input checked="" type="checkbox"/>	<input type="checkbox"/>
b) <i>Create a hazard to the public or the environment through reasonably foreseeable upset and accident conditions involving the release of hazardous materials into the environment?</i>	<input type="checkbox"/>	<input type="checkbox"/>	<input checked="" type="checkbox"/>	<input type="checkbox"/>
c) <i>Emit hazardous emissions or handle hazardous or acutely hazardous materials, substances, or waste within ¼-mile of an existing or proposed school?</i>	<input type="checkbox"/>	<input type="checkbox"/>	<input checked="" type="checkbox"/>	<input type="checkbox"/>
d) <i>Be located on, or adjacent to, a site which is included on a list of hazardous material/waste sites compiled pursuant to Gov't Code 65962.5 ("Cortese List"), and result in an adverse public health condition?</i>	<input type="checkbox"/>	<input type="checkbox"/>	<input type="checkbox"/>	<input checked="" type="checkbox"/>
e) <i>Impair implementation or physically interfere with an adopted emergency response or evacuation plan?</i>	<input type="checkbox"/>	<input type="checkbox"/>	<input checked="" type="checkbox"/>	<input type="checkbox"/>



**7. HAZARDS & HAZARDOUS MATERIALS - Will the project:**

	Potentially Significant	Impact can & will be mitigated	Insignificant Impact	Not Applicable
f) <i>If within the Airport Review designation, or near a private airstrip, result in a safety hazard for people residing or working in the project area?</i>	<input type="checkbox"/>	<input type="checkbox"/>	<input checked="" type="checkbox"/>	<input type="checkbox"/>
g) <i>Increase fire hazard risk or expose people or structures to high wildland fire hazard conditions?</i>	<input type="checkbox"/>	<input type="checkbox"/>	<input checked="" type="checkbox"/>	<input type="checkbox"/>
h) <i>Be within a 'very high' fire hazard severity zone?</i>	<input type="checkbox"/>	<input type="checkbox"/>	<input checked="" type="checkbox"/>	<input type="checkbox"/>
i) <i>Be within an area classified as a 'state responsibility' area as defined by CalFire?</i>	<input type="checkbox"/>	<input type="checkbox"/>	<input checked="" type="checkbox"/>	<input type="checkbox"/>
j) <i>Other: _____</i>	<input type="checkbox"/>	<input type="checkbox"/>	<input type="checkbox"/>	<input checked="" type="checkbox"/>

**Hazards and Hazardous Materials**

**Setting.** The project is not located in an area of known hazardous material contamination. The project is not within a 'high' or 'very high' severity risk area for fire. The project is within the Paso Robles Airport Review area. Due to location, fire hazard severity data is unavailable. Based on the County's fire response time map, it will take approximately 10-15 minutes to respond to a call regarding fire or life safety. Refer to the Public Services section for further discussion on Fire Safety impacts.

**Impact.** The project does not propose the use of hazardous materials, nor the generation of hazardous wastes. The proposed project is not found on the 'Cortese List' (which is a list of hazardous materials sites compiled pursuant to Government Code Section 65962.5). The project does not present a significant fire safety risk. The project is not expected to conflict with any regional emergency response or evacuation plan.

The project site, located approximately 1 mile north of the City of Paso Robles served by paved, collector road. The nearest Cal Fire / County Fire facility is located 2 road miles away at 98 Los Robles Camp, Paso Robles. The project does not present a significant fire safety risk.

The project is subject to the implementation of a Fire Safety Plan, as approved by County Fire/Cal Fire. The fire safety plan addresses issues such as access road design, replacement of hydrants, storage of water, sprinklering, building materials, and vegetation clearance. Compliance with the fire safety plan will ensure that impacts due to fire hazard are reduced to a less-than-significant level.

The project is not expected to conflict with any regional emergency response or evacuation plan. The proposed project does not appear to create any additional noise, safety, airspace projection, or overflight.

**Mitigation/Conclusion.** No significant impacts as a result of hazards or hazardous materials are anticipated, and no mitigation measures are necessary.



## 8. NOISE

	Potentially Significant	Impact can & will be mitigated	Insignificant Impact	Not Applicable
<i>Will the project:</i>				
a) <i>Expose people to noise levels that exceed the County Noise Element thresholds?</i>	<input type="checkbox"/>	<input type="checkbox"/>	<input checked="" type="checkbox"/>	<input type="checkbox"/>
b) <i>Generate permanent increases in the ambient noise levels in the project vicinity?</i>	<input type="checkbox"/>	<input type="checkbox"/>	<input checked="" type="checkbox"/>	<input type="checkbox"/>
c) <i>Cause a temporary or periodic increase in ambient noise in the project vicinity?</i>	<input type="checkbox"/>	<input type="checkbox"/>	<input checked="" type="checkbox"/>	<input type="checkbox"/>
d) <i>Expose people to severe noise or vibration?</i>	<input type="checkbox"/>	<input type="checkbox"/>	<input checked="" type="checkbox"/>	<input type="checkbox"/>
e) <i>If located within the Airport Review designation or adjacent to a private airstrip, expose people residing or working in the project area to severe noise levels?</i>	<input type="checkbox"/>	<input type="checkbox"/>	<input checked="" type="checkbox"/>	<input type="checkbox"/>
f) <i>Other:</i> _____	<input type="checkbox"/>	<input type="checkbox"/>	<input type="checkbox"/>	<input checked="" type="checkbox"/>

### Noise

**Setting.** The project is not considered a “noise sensitive land use” and is not within close proximity of loud noise sources. Based on the Noise Element’s projected future noise generation from known stationary and vehicle-generated noise sources, the project is within an acceptable threshold area.

The project is within the Airport Review designation and the area is subject to relatively low aircraft flyovers.

**Impact.** The project is not expected to generate loud noises, nor conflict with the surrounding uses. The project is located within an agricultural area and based on the Noise Element’s projected future noise generation from known stationary and vehicle-generated noise sources, the project is within an acceptable threshold area. The project would not generate loud noises, nor conflict with the surrounding uses. A single-family residence would not generate an increase in existing noise levels and the project would not expose people to significant increased noise levels in the long term.

During the construction phase of the project, noise generated from construction activities may intermittently dominate the noise environment in the immediate area. Short-term construction noise would be limited in nature and duration. Construction-related noise would not be substantially different from existing farm equipment uses and construction activities would be limited to the daytime hours of 7:00 a.m. to 9:00 p.m. Monday through Friday, and 8:00 a.m. to 5:00 p.m. on Saturday or Sunday, consistent with County construction noise exception standards (County Code Section 22.10.120.A). Therefore, potential construction-related noise impacts would be less than significant.

**Mitigation/Conclusion.** No long-term change in noise levels would occur. Short-term construction related noise would be limited in nature and duration and would only occur during appropriate daytime hours. Therefore, no additional mitigation measures beyond those outlined in the Land Use Ordinance are required.

## 9. POPULATION/HOUSING

*Will the project:*

	Potentially Significant	Impact can & will be mitigated	Insignificant Impact	Not Applicable
a) <i>Induce substantial growth in an area either directly (e.g., construct new homes or businesses) or indirectly (e.g., extension of major infrastructure)?</i>	<input type="checkbox"/>	<input type="checkbox"/>	<input checked="" type="checkbox"/>	<input type="checkbox"/>
b) <i>Displace existing housing or people, requiring construction of replacement housing elsewhere?</i>	<input type="checkbox"/>	<input type="checkbox"/>	<input checked="" type="checkbox"/>	<input type="checkbox"/>
c) <i>Create the need for substantial new housing in the area?</i>	<input type="checkbox"/>	<input type="checkbox"/>	<input checked="" type="checkbox"/>	<input type="checkbox"/>
d) <i>Other:</i> _____	<input type="checkbox"/>	<input type="checkbox"/>	<input type="checkbox"/>	<input checked="" type="checkbox"/>

### Population/Housing

**Setting** In its efforts to provide for affordable housing, the county currently administers the Home Investment Partnerships (HOME) Program and the Community Development Block Grant (CDBG) program, which provides limited financing to projects relating to affordable housing throughout the county. The County's Inclusionary Housing Ordinance requires provision of new affordable housing in conjunction with both residential and nonresidential development and subdivisions.

**Impact.** The project will not result in a need for a significant amount of new housing, and will not displace existing housing.

**Mitigation/Conclusion.** No significant population and housing impacts are anticipated. No mitigation measures are necessary.

## 10. PUBLIC SERVICES/UTILITIES

*Will the project have an effect upon, or result in the need for new or altered public services in any of the following areas:*

	Potentially Significant	Impact can & will be mitigated	Insignificant Impact	Not Applicable
a) <i>Fire protection?</i>	<input type="checkbox"/>	<input type="checkbox"/>	<input checked="" type="checkbox"/>	<input type="checkbox"/>
b) <i>Police protection (e.g., Sheriff, CHP)?</i>	<input type="checkbox"/>	<input type="checkbox"/>	<input checked="" type="checkbox"/>	<input type="checkbox"/>
c) <i>Schools?</i>	<input type="checkbox"/>	<input type="checkbox"/>	<input checked="" type="checkbox"/>	<input type="checkbox"/>
d) <i>Roads?</i>	<input type="checkbox"/>	<input type="checkbox"/>	<input checked="" type="checkbox"/>	<input type="checkbox"/>
e) <i>Solid Wastes?</i>	<input type="checkbox"/>	<input type="checkbox"/>	<input checked="" type="checkbox"/>	<input type="checkbox"/>
f) <i>Other public facilities?</i>	<input type="checkbox"/>	<input type="checkbox"/>	<input type="checkbox"/>	<input checked="" type="checkbox"/>
g) <i>Other:</i> _____	<input type="checkbox"/>	<input type="checkbox"/>	<input type="checkbox"/>	<input checked="" type="checkbox"/>

**Setting.** The project area is served by the following public services/facilities:



Police: County Sheriff

Location: Templeton (Approximately 13 miles to the south)

Fire: Cal Fire (formerly CDF)

Hazard Severity: Not Available

Response Time: 5-15 minutes

Location: 98 Los Robles Camp, Paso Robles (Approximately 2 miles south)

School District: Paso Robles Joint Unified School District and San Luis Obispo Joint Community College District

### Public Services

For additional information regarding fire hazard impacts, go to the 'Hazards and Hazardous Materials' section.

**Impact.** No significant project-specific impacts to utilities or public services were identified. This project, along with others in the area, will have a cumulative effect on police/sheriff and fire protection, and schools. The project’s direct and cumulative impacts are within the general assumptions of allowed use for the subject property that was used to estimate the fees in place.

**Mitigation/Conclusion.** No significant impacts to public services or utilities would occur. No mitigation measures are necessary.

## 11. RECREATION

	Potentially Significant	Impact can & will be mitigated	Insignificant Impact	Not Applicable
<i>Will the project:</i>				
a) <i>Increase the use or demand for parks or other recreation opportunities?</i>	<input type="checkbox"/>	<input type="checkbox"/>	<input checked="" type="checkbox"/>	<input type="checkbox"/>
b) <i>Affect the access to trails, parks or other recreation opportunities?</i>	<input type="checkbox"/>	<input type="checkbox"/>	<input checked="" type="checkbox"/>	<input type="checkbox"/>
c) <i>Other _____</i>	<input type="checkbox"/>	<input type="checkbox"/>	<input type="checkbox"/>	<input checked="" type="checkbox"/>

### Recreation

**Setting.** The County’s Parks and Recreation Element does not show that a potential trail goes through the proposed project. The project is not proposed in a location that will affect any trail, park, recreational resource, coastal access, and/or Natural Area.

**Impact.** The project will not create a significant need for additional park, Natural Area, and/or recreational resources.

**Mitigation/Conclusion.** No significant recreation impacts are anticipated, and no mitigation measures are necessary.

## 12. TRANSPORTATION/CIRCULATION

	Potentially Significant	Impact can & will be mitigated	Insignificant Impact	Not Applicable
<i>Will the project:</i>				
a) <i>Increase vehicle trips to local or areawide circulation system?</i>	<input type="checkbox"/>	<input type="checkbox"/>	<input checked="" type="checkbox"/>	<input type="checkbox"/>
b) <i>Reduce existing “Level of Service” on public roadway(s)?</i>	<input type="checkbox"/>	<input type="checkbox"/>	<input checked="" type="checkbox"/>	<input type="checkbox"/>



## 12. TRANSPORTATION/CIRCULATION

	Potentially Significant	Impact can & will be mitigated	Insignificant Impact	Not Applicable
<i>Will the project:</i>				
c) <i>Create unsafe conditions on public roadways (e.g., limited access, design features, sight distance, slow vehicles)?</i>	<input type="checkbox"/>	<input type="checkbox"/>	<input checked="" type="checkbox"/>	<input type="checkbox"/>
d) <i>Provide for adequate emergency access?</i>	<input type="checkbox"/>	<input type="checkbox"/>	<input checked="" type="checkbox"/>	<input type="checkbox"/>
e) <i>Conflict with an established measure of effectiveness for the performance of the circulation system considering all modes of transportation (e.g. LOS, mass transit, etc.)?</i>	<input type="checkbox"/>	<input type="checkbox"/>	<input checked="" type="checkbox"/>	<input type="checkbox"/>
f) <i>Conflict with an applicable congestion management program?</i>	<input type="checkbox"/>	<input type="checkbox"/>	<input checked="" type="checkbox"/>	<input type="checkbox"/>
g) <i>Conflict with adopted policies, plans, or programs regarding public transit, bicycle, or pedestrian facilities, or otherwise decrease the performance or safety of such facilities?</i>	<input type="checkbox"/>	<input type="checkbox"/>	<input checked="" type="checkbox"/>	<input type="checkbox"/>
h) <i>Result in a change in air traffic patterns that may result in substantial safety risks?</i>	<input type="checkbox"/>	<input type="checkbox"/>	<input checked="" type="checkbox"/>	<input type="checkbox"/>
i) <i>Other:</i> _____	<input type="checkbox"/>	<input type="checkbox"/>	<input type="checkbox"/>	<input checked="" type="checkbox"/>

### Transportation

**Setting.** The County has established the acceptable Level of Service (LOS) on roads for this rural area as “C” or better. The existing road network in the area is operating at acceptable levels. Based on existing road speeds and configuration, sight distance is considered acceptable. Public Works reviewed the project, and no significant traffic-related concerns were identified. The project is not located within a County road fee area.

The project is within the County’s Airport Review combining designation (AR). The AR is used to recognize and minimize the potential conflict between new development around the Paso Robles Municipal airport and the ability of aircraft to safely and efficiently maneuver to and from this airport. This includes additional standards relating to limiting structure/vegetation heights as well as avoiding airport operation conflicts (e.g., exterior lighting, radio/electronic interference, etc.). The Airport Land Use Plan (ALUP) provides guidance for and limitations to the type of development allowed within the AR designation. Per the ALUP, the proposed use is considered compatible.

**Impact.** The proposed project is estimated to generate about 10 trips per day, based on the Institute of Traffic Engineer’s manual of 10/unit. This small amount of additional traffic will not result in a significant change to the existing road service or traffic safety levels. The project does not conflict with adopted policies, plans and programs on transportation.

**Mitigation/Conclusion.** Applicant will not be required to obtain an avigation easement per Section 22.14.030 Airport Review Area (AR). No significant traffic impacts were identified, and no mitigation measures above what are already required by ordinance are necessary.





### 13. WASTEWATER

<i>Will the project:</i>	Potentially Significant	Impact can & will be mitigated	Insignificant Impact	Not Applicable
a) <i>Violate waste discharge requirements or Central Coast Basin Plan criteria for wastewater systems?</i>	<input type="checkbox"/>	<input type="checkbox"/>	<input checked="" type="checkbox"/>	<input type="checkbox"/>
b) <i>Change the quality of surface or ground water (e.g., nitrogen-loading, daylighting)?</i>	<input type="checkbox"/>	<input type="checkbox"/>	<input checked="" type="checkbox"/>	<input type="checkbox"/>
c) <i>Adversely affect community wastewater service provider?</i>	<input type="checkbox"/>	<input type="checkbox"/>	<input checked="" type="checkbox"/>	<input type="checkbox"/>
d) <i>Other:</i> _____	<input type="checkbox"/>	<input type="checkbox"/>	<input type="checkbox"/>	<input checked="" type="checkbox"/>

#### Wastewater

Regulations and guidelines on proper wastewater system design and criteria are found within the Water Quality Control Policy for Siting, Design, Operation, and Maintenance of Onsite Wastewater Treatment Systems (California OWTS Policy), and the California Plumbing Code. These regulations include specific requirements for both on-site and community wastewater systems and are applied to all new wastewater systems.

The California OWTS Policy includes the option for public agencies in California to prepare and implement a Local Agency Management Program (LAMP), subject to approval by the Central Coast Water Board. Once adopted, the LAMP will ensure local agency approval and permitting of onsite wastewater treatment systems protective of groundwater quality and public health and will incorporate updated standards applicable to onsite wastewater treatment systems. At this time, the California OWTS Policy standards supercede San Luis Obispo County Codes in Title 19. Until the County's LAMP is approved, the County permitting authority is limited to OWTS that meet Tier 1 requirements, as defined by the California OWTS Policy and summarized in the County's **Updated Criteria Policy Document BLD-2028 (dated 06/21/18)**. All other onsite wastewater disposal systems, including all seepage pit systems, must be approved and permitted through the Central Coast Water Board.

For onsite wastewater treatment (septic) systems, there are several key factors to consider for a system to operate successfully, including the following:

- ✓ Sufficient land area to meet the criteria for as currently established in Tier 1 Standards of the California OWTS Policy; depending on rainfall amount, and percolation rate, required parcel size minimums will range from one acre to 2.5 acres;
- ✓ The soil's ability to percolate or "filter" effluent before reaching groundwater supplies (30 to 120 minutes per inch is ideal);
- ✓ The soil's depth (there needs to be adequate separation from bottom of leach line to bedrock [at least 10 feet] or high groundwater [5 feet to 50 feet depending on percolation rates]);
- ✓ The soil's slope on which the system is placed (surface areas too steep creates potential for daylighting of effluent);
- ✓ Distance from existing or proposed wells (between 100 and 250 feet depending on circumstances); and
- ✓ Distance from creeks and water bodies (100-foot minimum).

To assure a septic system can meet existing regulation criteria, proper conditions are critical. Above-ground conditions are typically straight-forward and most easily addressed. Below ground criteria may require additional analysis or engineering when one or more factors exist:

- ✓ the ability of the soil to “filter” effluent is either too fast (percolation rate is faster or less than 30 minutes per inch and has “poor filtering” characteristics) or is too slow (slower or more than 120 minutes per inch);
- ✓ the topography on which a system is placed is steep enough to potentially allow “daylighting” of effluent downslope; or
- ✓ the separation between the bottom of the leach line to bedrock or high groundwater is inadequate.

**Analysis.** Based on Natural Resource Conservation Service (NRCS) Soil Survey map, the soil type(s) for the project as provided in the previous Agricultural Resource section is Arbuckle-Positas complex (15 - 30 % slope) and Arbuckle-San Ysidro complex (2 - 9% slope).

The proposed four-bedroom single-family residence is estimated to generate up to 480 gallons of wastewater per day. Under the California OWTS Policy Tier 1 criteria general guidelines, the site’s percolation rate of 36 inches per minute for an assumed 480 gallons per day requires a minimum of 180 linear feet of trench for high-capacity leaching chambers. Project plans indicate two rows of 100 foot long trenches (200 linear feet), with 100% expansion area identified. Based on the annual average rainfall, the project site is located in an area receiving 14 inches of annual rainfall and requires a minimum of 2.5 acres per residential unit. The site is 36.95 acres in size.

**Impacts/Mitigation.** Based on the following project conditions or design features, wastewater impacts are considered less than significant:

- ✓ The project has sufficient land area per the County’s Land Use Ordinance to support an on-site system;
- ✓ The soil’s percolation rate is between 30 to 120 minutes per inch;
- ✓ There is adequate soil separation between the bottom of the leach line to bedrock or high groundwater;
- ✓ The soil’s slope is less than 20%;
- ✓ The leach lines are outside of the 100-year flood hazard area;
- ✓ There is adequate distance between proposed leach lines and existing or proposed wells;
- ✓ The leach lines are at least 100 feet from creeks and water bodies.

No additional measures above what is already required for a standard septic system is needed.

**Conclusion.** Based on the above discussion and information provided, there appears to be adequate evidence showing that on-site disposal systems can be designed to meet the CPC/California OWTS Policy Tier 1 Criteria. Prior to building permit issuance and/or final inspection of the wastewater system, the applicant will need to show to the county compliance with the California OWTS Policy Tier 1 Criteria, including any above-discussed information relating to potential constraints, or obtain approval from the Central Coast Water Board for the OWTS in the event that the design does not meet Tier 1 criteria. Therefore, based on the project being able to comply with these regulations, potential groundwater quality impacts are considered less than significant.

## 14. WATER & HYDROLOGY

*Will the project:*

### QUALITY

a) *Violate any water quality standards?*

Potentially Significant	Impact can & will be mitigated	Insignificant Impact	Not Applicable
-------------------------	--------------------------------	----------------------	----------------

<input type="checkbox"/>	<input type="checkbox"/>	<input checked="" type="checkbox"/>	<input type="checkbox"/>
--------------------------	--------------------------	-------------------------------------	--------------------------

b) *Discharge into surface waters or otherwise alter surface water quality (e.g., turbidity, sediment, temperature, dissolved oxygen, etc.)?*

<input type="checkbox"/>	<input type="checkbox"/>	<input checked="" type="checkbox"/>	<input type="checkbox"/>
--------------------------	--------------------------	-------------------------------------	--------------------------

c) *Change the quality of groundwater (e.g., saltwater intrusion, nitrogen-loading, etc.)?*

<input type="checkbox"/>	<input type="checkbox"/>	<input checked="" type="checkbox"/>	<input type="checkbox"/>
--------------------------	--------------------------	-------------------------------------	--------------------------

d) *Create or contribute runoff water which would exceed the capacity of existing or planned stormwater drainage systems or provide additional sources of polluted runoff?*

<input type="checkbox"/>	<input type="checkbox"/>	<input checked="" type="checkbox"/>	<input type="checkbox"/>
--------------------------	--------------------------	-------------------------------------	--------------------------

e) *Change rates of soil absorption, or amount or direction of surface runoff?*

<input type="checkbox"/>	<input checked="" type="checkbox"/>	<input type="checkbox"/>	<input type="checkbox"/>
--------------------------	-------------------------------------	--------------------------	--------------------------

f) *Change the drainage patterns where substantial on- or off-site sedimentation/ erosion or flooding may occur?*

<input type="checkbox"/>	<input type="checkbox"/>	<input checked="" type="checkbox"/>	<input type="checkbox"/>
--------------------------	--------------------------	-------------------------------------	--------------------------

g) *Involve activities within the 100-year flood zone?*

<input type="checkbox"/>	<input type="checkbox"/>	<input checked="" type="checkbox"/>	<input type="checkbox"/>
--------------------------	--------------------------	-------------------------------------	--------------------------

### QUANTITY

h) *Change the quantity or movement of available surface or ground water?*

<input type="checkbox"/>	<input type="checkbox"/>	<input checked="" type="checkbox"/>	<input type="checkbox"/>
--------------------------	--------------------------	-------------------------------------	--------------------------

i) *Adversely affect community water service provider?*

<input type="checkbox"/>	<input type="checkbox"/>	<input checked="" type="checkbox"/>	<input type="checkbox"/>
--------------------------	--------------------------	-------------------------------------	--------------------------

j) *Expose people to a risk of loss, injury or death involving flooding (e.g., dam failure, etc.), or inundation by seiche, tsunami or mudflow?*

<input type="checkbox"/>	<input type="checkbox"/>	<input checked="" type="checkbox"/>	<input type="checkbox"/>
--------------------------	--------------------------	-------------------------------------	--------------------------

k) *Other:* \_\_\_\_\_

<input type="checkbox"/>	<input type="checkbox"/>	<input type="checkbox"/>	<input checked="" type="checkbox"/>
--------------------------	--------------------------	--------------------------	-------------------------------------

### Water

**Setting.** The proposed project is within the Salinas/Estrella water planning area. The project proposes to obtain its water needs from an existing on-site well. The project site and well location are within the Paso Robles Ground Water Basin, which is an LOS III groundwater basin.

The topography of the project site is nearly level to gently rolling. The closest creek from the proposed development is an ephemeral creek approximately 350 feet to the north. As described in the NRCS Soil Survey, the soil surface is considered to have moderate erodibility.

Projects involving more than one acre of disturbance are subject to preparing a Storm Water Pollution Prevention Plan (SWPPP) to minimize on-site sedimentation and erosion, however, agricultural



reservoirs are exempt from SWPPP. When work is done in the rainy season, the County's Land Use Ordinance requires that temporary erosion and sedimentation measures to be installed.

**DRAINAGE** – The following relates to the project's drainage aspects:

Within the 100-year Flood Hazard designation? No

Closest creek? Unnamed tributaries to Estrella River Distance? onsite

Soil drainage characteristics: Moderately drained to not well drained

For areas where drainage is identified as a potential issue, the Land Use Ordinance (LUO Sec. 22.52.110) includes a provision to prepare a drainage plan to minimize potential drainage impacts. When required, this plan would need to address measures such as: constructing on-site retention or detention basins, or installing surface water flow dissipaters. This plan would also need to show that the increased surface runoff would have no more impacts than that caused by historic flows.

**SEDIMENTATION AND EROSION** – Soil type, area of disturbance, and slopes are key aspects to analyzing potential sedimentation and erosion issues. The project's soil types and descriptions are listed in the previous Agriculture section under "Setting". As described in the NRCS Soil Survey, the project's soil erodibility is as follows:

Soil erodibility: Moderate

A sedimentation and erosion control plan is required for all construction and grading projects (LUO Sec. 22.52.120) to minimize these impacts. When required, the plan is prepared by a civil engineer to address both temporary and long-term sedimentation and erosion impacts. Projects involving more than one acre of disturbance are subject to the preparation and implementation of a Storm Water Pollution Prevention Plan (SWPPP) which focuses on controlling storm water runoff and must enroll for coverage under California's Construction General Permit. The Regional Water Quality Control Board is the local extension who monitors this program.

Section 19.07.042(d) of the Building and Construction Ordinance, Title 19, requires Offset Clearance from the Department of Planning and Building for projects overlying the Paso Groundwater Basin, prior to building permit issuance, verifying that new water use has been offset at a 1:1 ratio. This standard does apply to the proposed project since it would use an existing well.

### **Impact – Water Quality/Hydrology**

With regards to project impacts on water quality the following conditions apply:

- ✓ Approximately 72,310 square feet (1.66 acres) of site disturbance is proposed and the movement of approximately 5,108 cubic yards of material;
- ✓ The project will be subject to standard County requirements for drainage, sedimentation and erosion control for construction and permanent use;
- ✓ The project is not on highly erodible soils, nor on moderate to steep slopes;
- ✓ The project is not within a 100-year Flood Hazard designation;
- ✓ The project is more than 100 feet from the closest creek or surface water body;
- ✓ Stockpiles will be properly managed during construction to avoid material loss due to erosion;
- ✓ All hazardous materials and/or wastes will be properly stored on-site, which include secondary containment should spills or leaks occur;

Implementation of these County standards would reduce the project's water quality impacts to less than significant.

### **Water Quantity**



Based on the project description, as calculated on the County's water usage [worksheet](#), the project's water usage is estimated as follows:

Indoor: 0.18 acre feet/year (AFY);  
Outdoor: 0.15 AFY  
Total Use: 0.33 AFY  
Water Conservation: 0.03 AFY  
Total Use w/ Conservation: 0.29 AFY

Sources used for this estimate include one or more of the following references: County's Land Use Ordinance, 2000 Census data, Pacific Institute studies (2003), City of Santa Barbara Water Demand Factor & Conservation Study 'User Guide' (1989).

The project includes the following measures required by ordinance to reduce consumptive water use:

- ✓ Outdoor landscaping is compliant with MWELO Water Budget requirements
- ✓ Indoor plumbing will meet current State and County water conservation standards

The existing well provides groundwater derived from the Paso Robles groundwater basin. According to the 2012-2014 Resource Summary Report, a Level of Severity III exists for water supply within the Paso Robles groundwater basin. The project is subject to the adopted water conservation requirements of the Countywide Water Conservation Program adopted by the County Board of Supervisors in October 2015 (Resolution 2015-288). This program requires all new development in the Paso Robles Groundwater Basin Area to be water neutral through water use offset requirements.

The project is located over the Paso Robles groundwater basin and is subject to applicable water offset requirements of Title 19 (Building and Construction Ordinance) and Title 22 (Land Use Ordinance):

- Section 19.07.042(d) of the Building and Construction Ordinance, Title 19 – Requires Offset Clearance from the Department of Planning and Building, prior to building permit issuance, verifying that new water use has been offset at a 1:1 ratio. Applies to all new structures with plumbing fixtures on properties that overlie the Paso Robles groundwater basin.
- Section 22.94.050 of the Land Use Ordinance, Title 22 – Requires discretionary development projects to offset new water demand at a 2:1 ratio through participation in water conservation programs. Exempts agricultural processing uses as defined in the Land Use Ordinance.

As depicted above, the project is anticipated to create an additional groundwater demand of approximately 0.29 acre-feet per year for the proposed residential development. The residential building permit will be subject to Title 19 water offset fees at building permit issuance.

**Mitigation/Conclusion.** As specified above for water quality, existing regulations and/or required plans will adequately address surface water quality impacts during construction and permanent use of the project. No additional measures above what are required or proposed are needed to protect water quality. Based on the proposed amount of water to be used and required payment of water offset fees by ordinance to offset impacts to the water source, no significant impacts from water use are anticipated.



**15. LAND USE**

*Will the project:*

	Inconsistent	Potentially Inconsistent	Consistent	Not Applicable
a) <i>Be potentially inconsistent with land use, policy/regulation (e.g., general plan [County Land Use Element and Ordinance], local coastal plan, specific plan, Clean Air Plan, etc.) adopted to avoid or mitigate for environmental effects?</i>	<input type="checkbox"/>	<input type="checkbox"/>	<input checked="" type="checkbox"/>	<input type="checkbox"/>
b) <i>Be potentially inconsistent with any habitat or community conservation plan?</i>	<input type="checkbox"/>	<input type="checkbox"/>	<input checked="" type="checkbox"/>	<input type="checkbox"/>
c) <i>Be potentially inconsistent with adopted agency environmental plans or policies with jurisdiction over the project?</i>	<input type="checkbox"/>	<input type="checkbox"/>	<input checked="" type="checkbox"/>	<input type="checkbox"/>
d) <i>Be potentially incompatible with surrounding land uses?</i>	<input type="checkbox"/>	<input type="checkbox"/>	<input checked="" type="checkbox"/>	<input type="checkbox"/>
e) <i>Other:</i> _____	<input type="checkbox"/>	<input type="checkbox"/>	<input type="checkbox"/>	<input checked="" type="checkbox"/>

**Land Use**

**Setting/Impact.** Surrounding uses are identified on Page 2 of the Initial Study. The proposed project was reviewed for consistency with policy and/or regulatory documents relating to the environment and appropriate land use (e.g., County Land Use Ordinance, General Plan, County Building Ordinance, etc.). Referrals were sent to outside agencies to review for policy consistencies (e.g., County Fire/CAL FIRE for Fire Code, APCD for Clean Air Plan, etc.). The project was found to be consistent with these documents (refer also to Exhibit A on reference documents used).

The project is not within or adjacent to a Habitat Conservation Plan area. The project is consistent or compatible with the surrounding uses as summarized on page 2 of this Initial Study.

The proposed project is subject to the following Planning Area Standard(s) as found in the County's LUO:

1. LUO Section 22.94 North County Planning Area
2. LUO Section 22.94.020 A Paso Robles Airport Review Area
3. LUO Section 22.94.080 Salinas River Sub- Area

**Mitigation/Conclusion.** No inconsistencies were identified and therefore no additional measures above what will already be required were determined necessary.

**16. MANDATORY FINDINGS OF SIGNIFICANCE**

*Will the project:*

	Potentially Significant	Impact can & will be mitigated	Insignificant Impact	Not Applicable
a) <i>Have the potential to degrade the quality of the environment, substantially reduce the habitat of a fish or wildlife species, cause a fish or wildlife population to drop below self-sustaining levels, threaten to eliminate a plant or animal community, reduce the number or restrict the range of a rare or endangered plant or animal or eliminate important</i>				



**examples of the major periods of California history or pre-history?**

**b) Have impacts that are individually limited, but cumulatively considerable? (“Cumulatively considerable” means that the incremental effects of a project are considerable when viewed in connection with the effects of past projects, the effects of other current projects, and the effects of probable future projects)**

**c) Have environmental effects which will cause substantial adverse effects on human beings, either directly or indirectly?**

For further information on CEQA or the County’s environmental review process, please visit the County’s web site at [www.sloplanning.org](http://www.sloplanning.org) under “Environmental Information”, or the California Environmental Resources Evaluation System at: <http://resources.ca.gov/ceqa/> for information about the California Environmental Quality Act.

## Exhibit A - Initial Study References and Agency Contacts

The County Planning Department has contacted various agencies for their comments on the proposed project. With respect to the subject application, the following have been contacted (marked with an ☒) and when a response was made, it is either attached or in the application file:

<u>Contacted</u>	<u>Agency</u>	<u>Response</u>
<input checked="" type="checkbox"/>	County Public Works Department	<b>Not Applicable</b>
<input type="checkbox"/>	County Environmental Health Services	<b>Not Applicable</b>
<input checked="" type="checkbox"/>	County Agricultural Commissioner's Office	<b>Not Applicable</b>
<input checked="" type="checkbox"/>	County Airport Manager	<b>Not Applicable</b>
<input type="checkbox"/>	Airport Land Use Commission	<b>Not Applicable</b>
<input type="checkbox"/>	Air Pollution Control District	<b>Not Applicable</b>
<input type="checkbox"/>	County Sheriff's Department	<b>Not Applicable</b>
<input type="checkbox"/>	Regional Water Quality Control Board	<b>Not Applicable</b>
<input type="checkbox"/>	CA Coastal Commission	<b>Not Applicable</b>
<input checked="" type="checkbox"/>	CA Department of Fish and Wildlife	<b>Not Applicable</b>
<input type="checkbox"/>	CA Department of Forestry (Cal Fire)	<b>Not Applicable</b>
<input type="checkbox"/>	CA Department of Transportation	<b>Not Applicable</b>
<input type="checkbox"/>	Community Services District	<b>Not Applicable</b>
<input type="checkbox"/>	Other _____	<b>Not Applicable</b>
<input checked="" type="checkbox"/>	Other <u>AB 52</u>	<b>Attached</b>

\*\* "No comment" or "No concerns"-type responses are usually not attached

The following checked ("☒") reference materials have been used in the environmental review for the proposed project and are hereby incorporated by reference into the Initial Study. The following information is available at the County Planning and Building Department.

<input checked="" type="checkbox"/> Project File for the Subject Application	<input type="checkbox"/> Design Plan
<u>County documents</u>	<input type="checkbox"/> Specific Plan
<input type="checkbox"/> Coastal Plan Policies	<input checked="" type="checkbox"/> Annual Resource Summary Report
<input checked="" type="checkbox"/> Framework for Planning (Coastal/Inland)	<input type="checkbox"/> Circulation Study
<input checked="" type="checkbox"/> General Plan (Inland/Coastal), includes all maps/elements; more pertinent elements:	<u>Other documents</u>
<input checked="" type="checkbox"/> Agriculture Element	<input checked="" type="checkbox"/> Clean Air Plan/APCD Handbook
<input checked="" type="checkbox"/> Conservation & Open Space Element	<input checked="" type="checkbox"/> Regional Transportation Plan
<input type="checkbox"/> Economic Element	<input checked="" type="checkbox"/> Uniform Fire Code
<input checked="" type="checkbox"/> Housing Element	<input checked="" type="checkbox"/> Water Quality Control Plan (Central Coast Basin – Region 3)
<input checked="" type="checkbox"/> Noise Element	<input checked="" type="checkbox"/> Archaeological Resources Map
<input type="checkbox"/> Parks & Recreation Element/Project List	<input checked="" type="checkbox"/> Area of Critical Concerns Map
<input checked="" type="checkbox"/> Safety Element	<input checked="" type="checkbox"/> Special Biological Importance Map
<input checked="" type="checkbox"/> Land Use Ordinance (Inland/Coastal)	<input checked="" type="checkbox"/> CA Natural Species Diversity Database
<input type="checkbox"/> Building and Construction Ordinance	<input checked="" type="checkbox"/> Fire Hazard Severity Map
<input checked="" type="checkbox"/> Public Facilities Fee Ordinance	<input checked="" type="checkbox"/> Flood Hazard Maps
<input type="checkbox"/> Real Property Division Ordinance	<input checked="" type="checkbox"/> Natural Resources Conservation Service Soil Survey for SLO County
<input checked="" type="checkbox"/> Affordable Housing Fund	<input checked="" type="checkbox"/> GIS mapping layers (e.g., habitat, streams, contours, etc.)
<input type="checkbox"/> Airport Land Use Plan	<input type="checkbox"/> Other
<input type="checkbox"/> Energy Wise Plan	
<input checked="" type="checkbox"/> Salinas River Area Plan and Update EIR	

In addition, the following project specific information and/or reference materials have been considered as a part of the Initial Study:

1. San Luis Obispo County Air Pollution Control District (APCD). 2001. *Clean Air Plan – San Luis Obispo County*. December 2001.
2. Natural Resources Conservation Service. *Web Soil Survey National Cooperative Soil Survey*. Accessed November 14, 2017.

## Exhibit B - Mitigation Summary Table

Per Public Resources Code Section 21081.6, the following measures also constitute the mitigation monitoring and/or reporting program that will reduce potentially significant impacts to less than significant levels. These measures will become conditions of approval (COAs) should the project be approved. The Lead Agency (County) or other Responsible Agencies, as specified in the following measures, are responsible to verify compliance with these COAs.

### Aesthetics

VS-1 **Aesthetics – Exterior Colors.** To minimize visual impacts from the proposed residence, exterior colors and materials shall be selected and applied to a) minimize the structure's massing, and 2) reduce the contrast between the proposed development and the surrounding environment. Colors shall be compatible with the prominent natural colors of the surrounding environment, including vegetation, rock outcrops, etc. Darker, non-reflective, earth tone colors shall be selected for walls, chimneys etc. and darker green, grey, slate blue, or brown colors for the roof elements. All color selections shall fall within a "chroma" and "value" of 6 or less, as described in the Munsell Book of Color (review copy available at County Planning).

### Biological Resources

BR-1 **Prior to issuance of grading and/or construction permits,** the applicant shall submit evidence to the County of San Luis Obispo, Department of Planning and Building, Environmental and Resource Management Division (County) (see contact information below) that states that one or a combination of the following three San Joaquin kit fox mitigation measures has been implemented:

- a. Provide for the protection in perpetuity, through acquisition of fee or a conservation easement of **3.36** acres of suitable habitat in the kit fox corridor area (e.g. within the San Luis Obispo County kit fox habitat area), either on-site or off-site, and provide for a non-wasting endowment to provide for management and monitoring of the property in perpetuity. Lands to be conserved shall be subject to the review and approval of the California Department of Fish and Game (Department) and the County.

This mitigation alternative (a), requires that all aspects of this program must be in place before County permit issuance or initiation of any ground disturbing activities.

- b. Deposit funds into an approved in-lieu fee program, which would provide for the protection in perpetuity of suitable habitat in the kit fox corridor area within San Luis Obispo County, and provide for a non-wasting endowment for management and monitoring of the property in perpetuity.

Mitigation alternative (b) above, can be completed by providing funds to The Nature Conservancy (TNC) pursuant to the Voluntary Fee-Based Compensatory Mitigation Program (Program). The Program was established in agreement between the Department and TNC to preserve San Joaquin kit fox habitat, and to provide a voluntary mitigation alternative to project proponents who must mitigate the impacts of projects in accordance with the California Environmental Quality Act (CEQA). The fee, payable to "The Nature Conservancy," would total **\$8,400.00**. This fee is calculated based on the current cost-per-unit of \$2500 per acre of mitigation, which is scheduled to be adjusted to address the increasing cost of property in San Luis Obispo County; your actual cost may increase

depending on the timing of payment. This fee must be paid after the Department provides written notification identifying your mitigation options but prior to County permit issuance and initiation of any ground disturbing activities.

- c. Purchase **3.36** in a Department-approved conservation bank, which would provide for the protection in perpetuity of suitable habitat within the kit fox corridor area and provide for a non-wasting endowment for management and monitoring of the property in perpetuity.

Mitigation alternative (c) above, can be completed by purchasing credits from the Palo Prieto Conservation Bank (see contact information below). The Palo Prieto Conservation Bank was established to preserve San Joaquin kit fox habitat, and to provide a voluntary mitigation alternative to project proponents who must mitigate the impacts of projects in accordance with the California Environmental Quality Act (CEQA). The cost for purchasing credits is payable to the owners of The Palo Prieto Conservation Bank, and would total **\$8,400.00**. This fee is calculated based on the current cost-per-credit of \$2500 per acre of mitigation. The fee is established by the conservation bank owner and may change at any time. Your actual cost may increase depending on the timing of payment. Purchase of credits must be completed prior to County permit issuance and initiation of any ground disturbing activities.

**BR-2 Prior to issuance of grading and/or construction permits**, the applicant shall provide evidence that they have retained a qualified biologist acceptable to the County Division of Environmental and Resource Management. The retained biologist shall perform the following monitoring activities:

- a. **Prior to issuance of grading and/or construction permits and within 30 days prior to initiation of site disturbance and/or construction**, the biologist shall conduct a pre-activity (i.e. pre-construction) survey for known or potential kit fox dens and submit a letter to the County reporting the date the survey was conducted, the survey protocol, survey results, and what measures were necessary (and completed), as applicable, to address any kit fox activity within the project limits.
- b. The qualified biologist shall conduct weekly site visits during site-disturbance activities (i.e. grading, disking, excavation, stock piling of dirt or gravel, etc.) that proceed longer than 14 days, for the purpose of monitoring compliance with required Mitigation Measures BR-3 through BR11. Site- disturbance activities lasting up to 14 days do not require weekly monitoring by the biologist unless observations of kit fox or their dens are made on-site or the qualified biologist recommends monitoring for some other reason (see BR-2-c3). When weekly monitoring is required, the biologist shall submit weekly monitoring reports to the County.
- c. **Prior to or during project activities**, if any observations are made of San Joaquin Kit fox, or any known or potential San Joaquin kit fox dens are discovered within the project limits, the qualified biologist shall re-assess the probability of incidental take (e.g. harm or death) to kit fox. At the time a den is discovered, the qualified biologist shall contact the U.S. Fish and Wildlife Service and the Department for guidance on possible additional kit fox protection measures to implement and whether or not a Federal and/or State incidental take permit is needed. If a potential den is encountered during construction, work shall stop until such time the U.S. Fish and Wildlife Service/Department determine it is appropriate to resume work.





If incidental take of kit fox during project activities is possible, **before project activities commence**, the applicant must consult with the U.S. Fish and Wildlife Service and the Department (see contact information below). The results of this consultation may require the applicant to obtain a Federal and/or State permit for incidental take during project activities. The applicant should be aware that the presence of kit foxes or known or potential kit fox dens at the project site could result in further delays of project activities.

- d. In addition, the qualified biologist shall implement the following measures:
1. **Within 30 days prior to initiation of site disturbance and/or construction**, fenced exclusion zones shall be established around all known and potential kit fox dens. Exclusion zone fencing shall consist of either large flagged stakes connected by rope or cord, or survey laths or wooden stakes prominently flagged with survey ribbon. Each exclusion zone shall be roughly circular in configuration with a radius of the following distance measured outward from the den or burrow entrances:
    - a) Potential kit fox den: 50 feet
    - b) Known or active kit fox den: 100 feet
    - c) Kit fox pupping den: 150 feet
  2. All foot and vehicle traffic, as well as all construction activities, including storage of supplies and equipment, shall remain outside of exclusion zones. Exclusion zones shall be maintained until all project-related disturbances have been terminated, and then shall be removed.
  3. If kit foxes or known or potential kit fox dens are found on site, daily monitoring during ground disturbing activities shall be required by a qualified biologist.

BR-3 **Prior to issuance of grading and/or construction permits**, the applicant shall clearly delineate as a note on the project plans, that: *“Speed signs of 25 mph (or lower) shall be posted for all construction traffic to minimize the probability of road mortality of the San Joaquin kit fox”*. Speed limit signs shall be installed on the project site **within 30 days prior to initiation of site disturbance and/or construction**. In addition, **prior to permit issuance and initiation of any ground disturbing activities**, conditions BR-3 through BR-11 of the Developer's Statement/Conditions of Approval shall be clearly delineated on project plans.

BR-4 **During the site disturbance and/or construction phase**, grading and construction activities after dusk shall be prohibited unless coordinated through the County, during which additional kit fox mitigation measures may be required.

BR-5 **Prior to issuance of grading and/or construction permit and within 30 days prior to initiation of site disturbance and/or construction**, all personnel associated with the project shall attend a worker education training program, conducted by a qualified biologist, to avoid or reduce impacts on sensitive biological resources (i.e. San Joaquin kit fox). At a minimum, as the program relates to the kit fox, the training shall include the kit fox's life history, all mitigation measures specified by the county, as well as any related biological report(s) prepared for the project. The applicant shall notify the County shortly prior to this meeting. A kit fox fact sheet shall also be developed prior to the training program, and distributed at the training program to all contractors, employers and other personnel involved with the construction of the project.

BR-6 **During the site-disturbance and/or construction phase**, to prevent entrapment of the San Joaquin kit fox, all excavation, steep-walled holes or trenches in excess of two feet in depth shall be covered at the close of each working day by plywood or similar materials, or provided with one or more escape ramps constructed of earth fill or wooden planks. Trenches shall also

be inspected for entrapped kit fox each morning prior to onset of field activities and immediately prior to covering with plywood at the end of each working day. Before such holes or trenches are filled, they shall be thoroughly inspected for entrapped kit fox. Any kit fox so discovered shall be allowed to escape before field activities resume, or removed from the trench or hole by a qualified biologist and allowed to escape unimpeded.

- BR-7 **During the site-disturbance and/or construction phase**, any pipes, culverts, or similar structures with a diameter of four inches or greater, stored overnight at the project site shall be thoroughly inspected for trapped San Joaquin kit foxes before the subject pipe is subsequently buried, capped, or otherwise used or moved in any way. If during the construction phase a kit fox is discovered inside a pipe, that section of pipe will not be moved, or if necessary, be moved only once to remove it from the path of activity, until the kit fox has escaped.
- BR-8 **During the site-disturbance and/or construction phase**, all food-related trash items such as wrappers, cans, bottles, and food scraps generated shall be disposed of in closed containers only and regularly removed from the site. Food items may attract San Joaquin kit foxes onto the project site, consequently exposing such animals to increased risk of injury or mortality. No deliberate feeding of wildlife shall be allowed.
- BR-9 **Prior to, during and after the site-disturbance and/or construction phase**, use of pesticides or herbicides shall be in compliance with all local, state and federal regulations. This is necessary to minimize the probability of primary or secondary poisoning of endangered species utilizing adjacent habitats, and the depletion of prey upon which San Joaquin kit foxes depend.
- BR-10 **During the site-disturbance and/or construction phase**, any contractor or employee that inadvertently kills or injures a San Joaquin kit fox or who finds any such animal either dead, injured, or entrapped shall be required to report the incident immediately to the applicant and County. In the event that any observations are made of injured or dead kit fox, the applicant shall immediately notify the U.S. Fish and Wildlife Service and the Department by telephone (see contact information below). In addition, formal notification shall be provided in writing within three working days of the finding of any such animal(s). Notification shall include the date, time, location and circumstances of the incident. Any threatened or endangered species found dead or injured shall be turned over immediately to the Department for care, analysis, or disposition.
- BR-11 **Prior to commencement of any construction**, to avoid conflicts with nesting raptors, construction activities shall not be allowed during to the nesting season (March to July), unless a County-approved, qualified biologist has surveyed the impact zone and determined that no nesting activities will be adversely impacted. At such time, if any evidence of nesting activities are found, the biologist will determine if any construction activities can occur during the nesting period and to what extent. The results of the surveys will be passed immediately to the County (Environmental Division), possibly with recommendations for variable buffer zones, as needed, around individual nests. The applicant agrees to incorporate those recommendations approved by the County.

**DEVELOPER'S STATEMENT FOR  
Labriola / Grading Permit / PMTG2018-00084**

The applicant agrees to incorporate the following measures into the project. These measures become a part of the project description and therefore become a part of the record of action upon which the environmental determination is based. All development activity must occur in strict compliance with the following mitigation measures. These measures shall be perpetual and run with the land. These measures are binding on all successors in interest of the subject property.

**Note:** The items contained in the boxes labeled "Monitoring" describe the County procedures to be used to ensure compliance with the mitigation measures.

The following mitigation measures address impacts that may occur as a result of the development of the project.

Per Public Resources Code Section 21081.6, the following measures also constitute the mitigation monitoring and/or reporting program that will reduce potentially significant impacts to less than significant levels. These measures will become conditions of approval (COAs) should the project be approved. The Lead Agency (County) or other Responsible Agencies, as specified in the following measures, are responsible to verify compliance with these COAs.

**Visual and Aesthetic Resources**

VR-1 **Aesthetics – Exterior Colors.** To minimize visual impacts from the proposed residence, exterior colors and materials shall be selected and applied to a) minimize the structure's massing, and 2) reduce the contrast between the proposed development and the surrounding environment. Colors shall be compatible with the prominent natural colors of the surrounding environment, including vegetation, rock outcrops, etc. Darker, non-reflective, earth tone colors shall be selected for walls, chimneys etc. and darker green, grey, slate blue, or brown colors for the roof elements. All color selections shall fall within a "chroma" and "value" of 6 or less, as described in the Munsell Book of Color (review copy available at County Planning).

**Monitoring: (Visual Recourse Measures VR-1)** Required at the time of application for construction permits. Compliance will be verified by the County Department of Planning and Building.

**Biological Resources  
San Joaquin Kit Fox**

Your project will impact 0.84 acres of San Joaquin kit fox habitat. Based on the results of previous Kit Fox Habitat Evaluations that have been conducted for the Salinas River Sub Area, the Department of Fish and Game (Department) has determined that the standard mitigation ratio for projects on parcels less than 40 acres in size has been established as 4:1. This means that all impacts be mitigated at a ratio of 4 acres conserved for each acre impacted. You agreed to accept the standard mitigation ratio of 4:1 for your project. Total compensatory

mitigation required for your project is 3.36, based on 4 times 0.84 acres impacted. The mitigation options identified in BR-1 through BR-11 apply to the proposed project only; should your project change, your mitigation obligation may also change, and a reevaluation of your mitigation measures would be required.

**BR-1 Prior to issuance of grading and/or construction permits**, the applicant shall submit evidence to the County of San Luis Obispo, Department of Planning and Building, Environmental and Resource Management Division (County) (see contact information below) that states that one or a combination of the following three San Joaquin kit fox mitigation measures has been implemented:

- a. Provide for the protection in perpetuity, through acquisition of fee or a conservation easement of **3.36** acres of suitable habitat in the kit fox corridor area (e.g. within the San Luis Obispo County kit fox habitat area), either on-site or off-site, and provide for a non-wasting endowment to provide for management and monitoring of the property in perpetuity. Lands to be conserved shall be subject to the review and approval of the California Department of Fish and Game (Department) and the County.

This mitigation alternative (a), requires that all aspects of this program must be in place before County permit issuance or initiation of any ground disturbing activities.

- b. Deposit funds into an approved in-lieu fee program, which would provide for the protection in perpetuity of suitable habitat in the kit fox corridor area within San Luis Obispo County, and provide for a non-wasting endowment for management and monitoring of the property in perpetuity.

Mitigation alternative (b) above, can be completed by providing funds to The Nature Conservancy (TNC) pursuant to the Voluntary Fee-Based Compensatory Mitigation Program (Program). The Program was established in agreement between the Department and TNC to preserve San Joaquin kit fox habitat, and to provide a voluntary mitigation alternative to project proponents who must mitigate the impacts of projects in accordance with the California Environmental Quality Act (CEQA). The fee, payable to "The Nature Conservancy," would total **\$8,400.00**. This fee is calculated based on the current cost-per-unit of \$2500 per acre of mitigation, which is scheduled to be adjusted to address the increasing cost of property in San Luis Obispo County; your actual cost may increase depending on the timing of payment. This fee must be paid after the Department provides written notification identifying your mitigation options but prior to County permit issuance and initiation of any ground disturbing activities.

- c. Purchase **3.36** in a Department-approved conservation bank, which would provide for the protection in perpetuity of suitable habitat within the kit fox corridor area and provide for a non-wasting endowment for management and monitoring of the property in perpetuity.

Mitigation alternative (c) above, can be completed by purchasing credits from the Palo Prieto Conservation Bank (see contact information below). The Palo Prieto Conservation Bank was established to preserve San Joaquin kit fox habitat, and to provide a voluntary mitigation alternative to project proponents who must mitigate the impacts of projects in accordance with the California Environmental Quality Act

(CEQA). The cost for purchasing credits is payable to the owners of The Palo Prieto Conservation Bank, and would total **\$8,400.00**. This fee is calculated based on the current cost-per-credit of \$2500 per acre of mitigation. The fee is established by the conservation bank owner and may change at any time. Your actual cost may increase depending on the timing of payment. Purchase of credits must be completed prior to County permit issuance and initiation of any ground disturbing activities.

**Monitoring:** Required prior to issuance of a grading and/or construction permit. Compliance will be verified by the County Division of Environmental and Resource Management.

BR-2 **Prior to issuance of grading and/or construction permits**, the applicant shall provide evidence that they have retained a qualified biologist acceptable to the County Division of Environmental and Resource Management. The retained biologist shall perform the following monitoring activities:

- a. **Prior to issuance of grading and/or construction permits and within 30 days prior to initiation of site disturbance and/or construction**, the biologist shall conduct a pre-activity (i.e. pre-construction) survey for known or potential kit fox dens and submit a letter to the County reporting the date the survey was conducted, the survey protocol, survey results, and what measures were necessary (and completed), as applicable, to address any kit fox activity within the project limits.
- b. The qualified biologist shall conduct weekly site visits during site-disturbance activities (i.e. grading, disking, excavation, stock piling of dirt or gravel, etc.) that proceed longer than 14 days, for the purpose of monitoring compliance with required Mitigation Measures BR-3 through BR11. Site- disturbance activities lasting up to 14 days do not require weekly monitoring by the biologist unless observations of kit fox or their dens are made on-site or the qualified biologist recommends monitoring for some other reason (see BR-2-c3). When weekly monitoring is required, the biologist shall submit weekly monitoring reports to the County.
- c. **Prior to or during project activities**, if any observations are made of San Joaquin Kit fox, or any known or potential San Joaquin kit fox dens are discovered within the project limits, the qualified biologist shall re-assess the probability of incidental take (e.g. harm or death) to kit fox. At the time a den is discovered, the qualified biologist shall contact the U.S. Fish and Wildlife Service and the Department for guidance on possible additional kit fox protection measures to implement and whether or not a Federal and/or State incidental take permit is needed. If a potential den is encountered during construction, work shall stop until such time the U.S. Fish and Wildlife Service/Department determine it is appropriate to resume work.

If incidental take of kit fox during project activities is possible, **before project activities commence**, the applicant must consult with the U.S. Fish and Wildlife Service and the Department (see contact information below). The results of this consultation may require the applicant to obtain a Federal and/or State permit for incidental take during project activities. The applicant should be aware that the presence of kit foxes or known or potential kit fox dens at the project site could result in further delays of project activities.

- d. In addition, the qualified biologist shall implement the following measures:
1. **Within 30 days prior to initiation of site disturbance and/or construction**, fenced exclusion zones shall be established around all known and potential kit fox dens. Exclusion zone fencing shall consist of either large flagged stakes connected by rope or cord, or survey laths or wooden stakes prominently flagged with survey ribbon. Each exclusion zone shall be roughly circular in configuration with a radius of the following distance measured outward from the den or burrow entrances:
    - a) Potential kit fox den: 50 feet
    - b) Known or active kit fox den: 100 feet
    - c) Kit fox pupping den: 150 feet
  2. All foot and vehicle traffic, as well as all construction activities, including storage of supplies and equipment, shall remain outside of exclusion zones. Exclusion zones shall be maintained until all project-related disturbances have been terminated, and then shall be removed.
  3. If kit foxes or known or potential kit fox dens are found on site, daily monitoring during ground disturbing activities shall be required by a qualified biologist.

**Monitoring:** Required prior to issuance of a grading and/or construction permit. Compliance will be verified by the County Division of Environmental and Resource Management .

- BR-3 **Prior to issuance of grading and/or construction permits**, the applicant shall clearly delineate as a note on the project plans, that: "*Speed signs of 25 mph (or lower) shall be posted for all construction traffic to minimize the probability of road mortality of the San Joaquin kit fox*". Speed limit signs shall be installed on the project site **within 30 days prior to initiation of site disturbance and/or construction**. In addition, **prior to permit issuance and initiation of any ground disturbing activities**, conditions BR-3 through BR-11 of the Developer's Statement/Conditions of Approval shall be clearly delineated on project plans.
- BR-4 **During the site disturbance and/or construction phase**, grading and construction activities after dusk shall be prohibited unless coordinated through the County, during which additional kit fox mitigation measures may be required.
- BR-5 **Prior to issuance of grading and/or construction permit and within 30 days prior to initiation of site disturbance and/or construction**, all personnel associated with the project shall attend a worker education training program, conducted by a qualified biologist, to avoid or reduce impacts on sensitive biological resources (i.e. San Joaquin kit fox). At a minimum, as the program relates to the kit fox, the training shall include the kit fox's life history, all mitigation measures specified by the county, as well as any related biological report(s) prepared for the project. The applicant shall notify the County shortly prior to this meeting. A kit fox fact sheet shall also be developed prior to the training program, and distributed at the training program to all contractors, employers and other personnel involved with the construction of the project.
- BR-6 **During the site-disturbance and/or construction phase**, to prevent entrapment of the



San Joaquin kit fox, all excavation, steep-walled holes or trenches in excess of two feet in depth shall be covered at the close of each working day by plywood or similar materials, or provided with one or more escape ramps constructed of earth fill or wooden planks. Trenches shall also be inspected for entrapped kit fox each morning prior to onset of field activities and immediately prior to covering with plywood at the end of each working day. Before such holes or trenches are filled, they shall be thoroughly inspected for entrapped kit fox. Any kit fox so discovered shall be allowed to escape before field activities resume, or removed from the trench or hole by a qualified biologist and allowed to escape unimpeded.

- BR-7 **During the site-disturbance and/or construction phase**, any pipes, culverts, or similar structures with a diameter of four inches or greater, stored overnight at the project site shall be thoroughly inspected for trapped San Joaquin kit foxes before the subject pipe is subsequently buried, capped, or otherwise used or moved in any way. If during the construction phase a kit fox is discovered inside a pipe, that section of pipe will not be moved, or if necessary, be moved only once to remove it from the path of activity, until the kit fox has escaped.
- BR-8 **During the site-disturbance and/or construction phase**, all food-related trash items such as wrappers, cans, bottles, and food scraps generated shall be disposed of in closed containers only and regularly removed from the site. Food items may attract San Joaquin kit foxes onto the project site, consequently exposing such animals to increased risk of injury or mortality. No deliberate feeding of wildlife shall be allowed.
- BR-9 **Prior to, during and after the site-disturbance and/or construction phase**, use of pesticides or herbicides shall be in compliance with all local, state and federal regulations. This is necessary to minimize the probability of primary or secondary poisoning of endangered species utilizing adjacent habitats, and the depletion of prey upon which San Joaquin kit foxes depend.
- BR-10 **During the site-disturbance and/or construction phase**, any contractor or employee that inadvertently kills or injures a San Joaquin kit fox or who finds any such animal either dead, injured, or entrapped shall be required to report the incident immediately to the applicant and County. In the event that any observations are made of injured or dead kit fox, the applicant shall immediately notify the U.S. Fish and Wildlife Service and the Department by telephone (see contact information below). In addition, formal notification shall be provided in writing within three working days of the finding of any such animal(s). Notification shall include the date, time, location and circumstances of the incident. Any threatened or endangered species found dead or injured shall be turned over immediately to the Department for care, analysis, or disposition.
- BR-11 **Prior to commencement of any construction**, to avoid conflicts with nesting raptors, construction activities shall not be allowed during to the nesting season (March to July), unless a County-approved, qualified biologist has surveyed the impact zone and determined that no nesting activities will be adversely impacted. At such time, if any evidence of nesting activities are found, the biologist will determine if any construction activities can occur during the nesting period and to what extent. The results of the surveys will be passed immediately to the County (Environmental Division), possibly with recommendations for variable buffer zones, as needed, around individual nests. The applicant agrees to incorporate those recommendations approved by the County.

**Monitoring (Biological Resource Measures BR-3 to BR-11)** Compliance will be verified by the County Department of Planning and Building, in consultation with the Environmental Coordinator.

The applicant understands that any changes made to the project description subsequent to this environmental determination must be reviewed by the Environmental Coordinator and may require a new environmental determination for the project. By signing this agreement, the owner(s) agrees to and accepts the incorporation of the above measures into the proposed project description.

  
\_\_\_\_\_  
Signature of Agent(s)

Raymond Tran  
\_\_\_\_\_  
Name (Print)

4/18/19  
\_\_\_\_\_  
Date

Miller Drilling Co.  
 329 N. Main St.  
 Templeton, CA 93465  
 (805) 434-1888

# Miller Drilling Co.

Contractors License No. 324634

## PUMP TEST REPORT

WELL OWNER:	<u>Mike Labriola</u>	Pump Set:	<u>400 ft</u>	Job#	<u>21262</u>
BILLING ADDRESS:	<u>2425 Golden Hill Rd #106-121</u>	Pump Size:	<u>1.5 hp</u>	Well #:	<u>5 inch</u>
	<u>Paso Robles, CA 93446</u>	Testing Method:	<u>existing pump</u>	Well Depth:	<u>600 ft</u>
	<u>mike@tigrisnet.net</u>	Perf Rec:	<u>560-600</u>		
		APN:	<u>027-191-072</u>		
Standing Level Before Test:	<u>333.10</u>	LOCATION:	<u>7005 Airport Road</u>		
			<u>Paso Robles, CA 93446</u>		

### TESTING

TIME	PUMPING LEVEL	WATER CONDITION	WATER/BOWLS	GPM
7:55am	336	CLEAR NO ODOR		11.6
8:00am	336	CLEAR NO ODOR		11.6
8:05am	336	CLEAR NO ODOR		11.6
8:10am	336.1	CLEAR NO ODOR		11.6
8:15am	336.1	CLEAR NO ODOR		11.6
8:20am	336.2	CLEAR NO ODOR		11.6
8:25am	336.3	CLEAR NO ODOR		11.6
8:30am	336.3	CLEAR NO ODOR		11.6
8:35am	336.5	CLEAR NO ODOR		11.6
8:40am	336.5	CLEAR NO ODOR		11.6
8:45am	336.5	CLEAR NO ODOR		11.6
8:50am	336.6	CLEAR NO ODOR		11.6
8:55am	336.6	CLEAR NO ODOR		11.6
11:30am	336.6	CLEAR NO ODOR		11.6
12:00pm	336.6	CLEAR NO ODOR		11.6
12:05pm	336.6	CLEAR NO ODOR		11.6

Notes: \_\_\_\_\_

STANDING LEVEL AFTER TEST: 334 (10 min recovery)  
 FINAL TEST RESULTS: Produced: 11.6 GPM for 4 hours on: 12/28/2018  
 Test Run By: Alex/Kurt

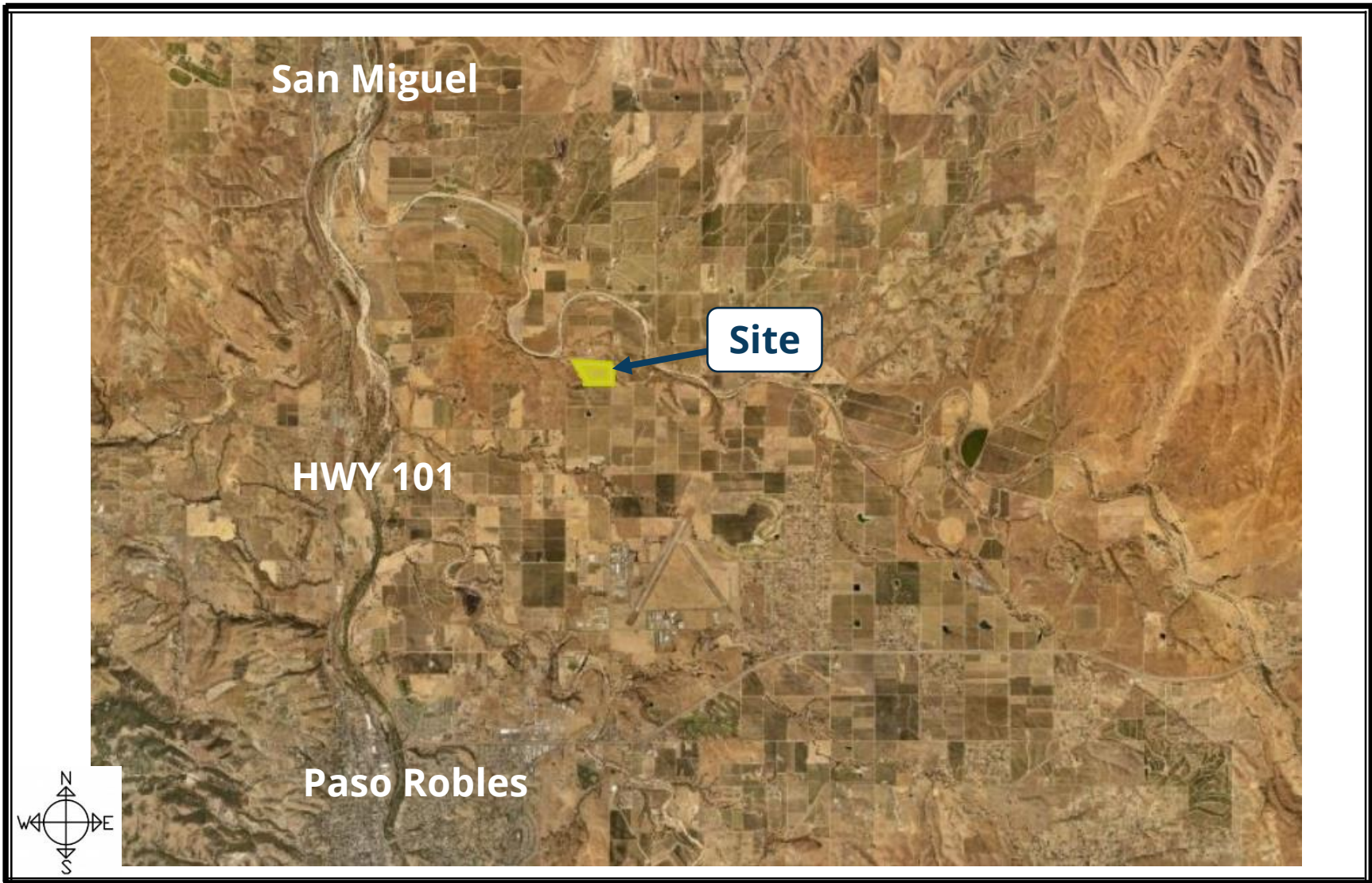

COUNTY OF SAN LUIS OBISPO

Vicinity Map  
PMTG2018-00084



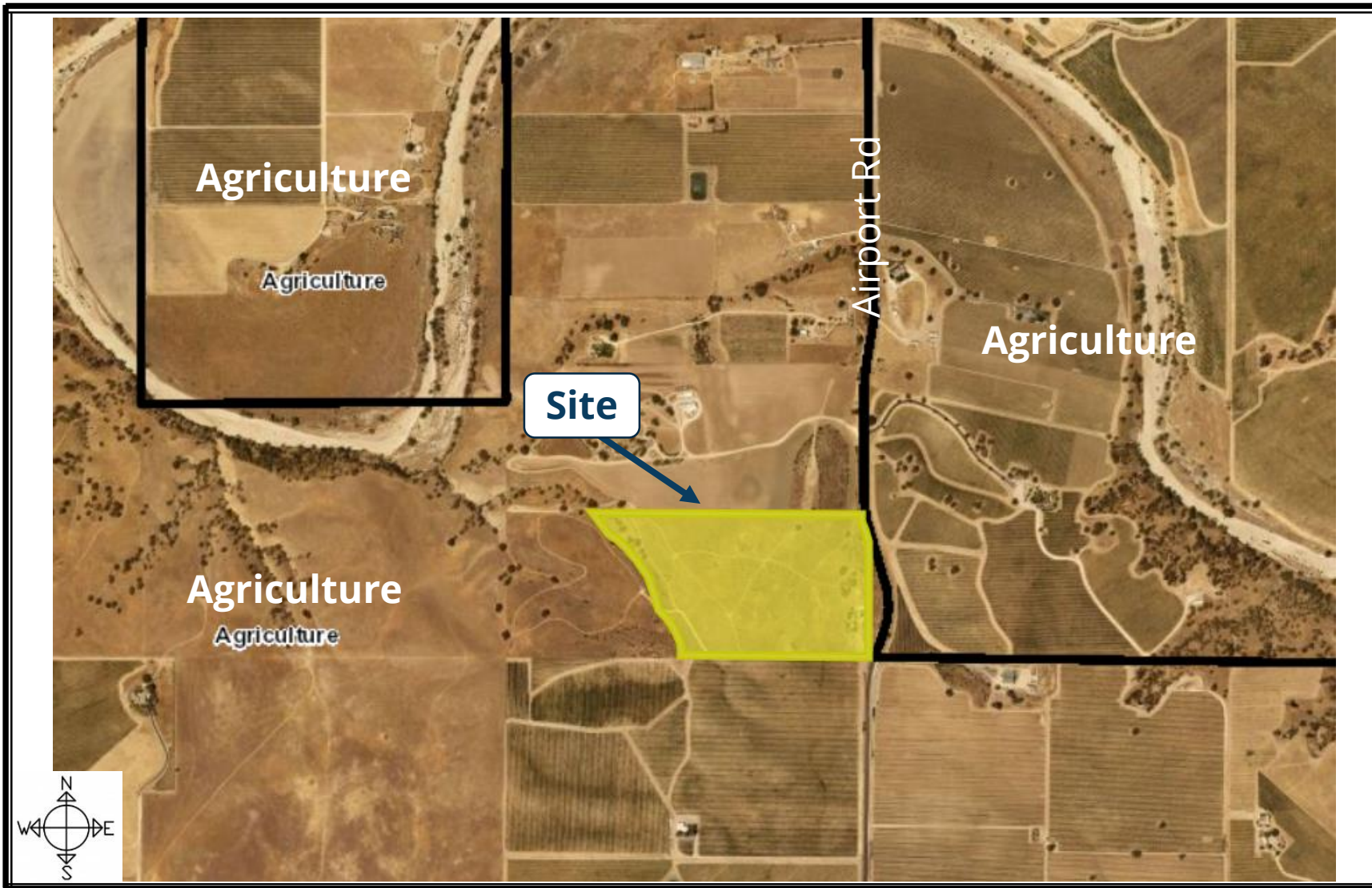

COUNTY OF SAN LUIS OBISPO

Land Use Category Map  
PMTG2018-00084

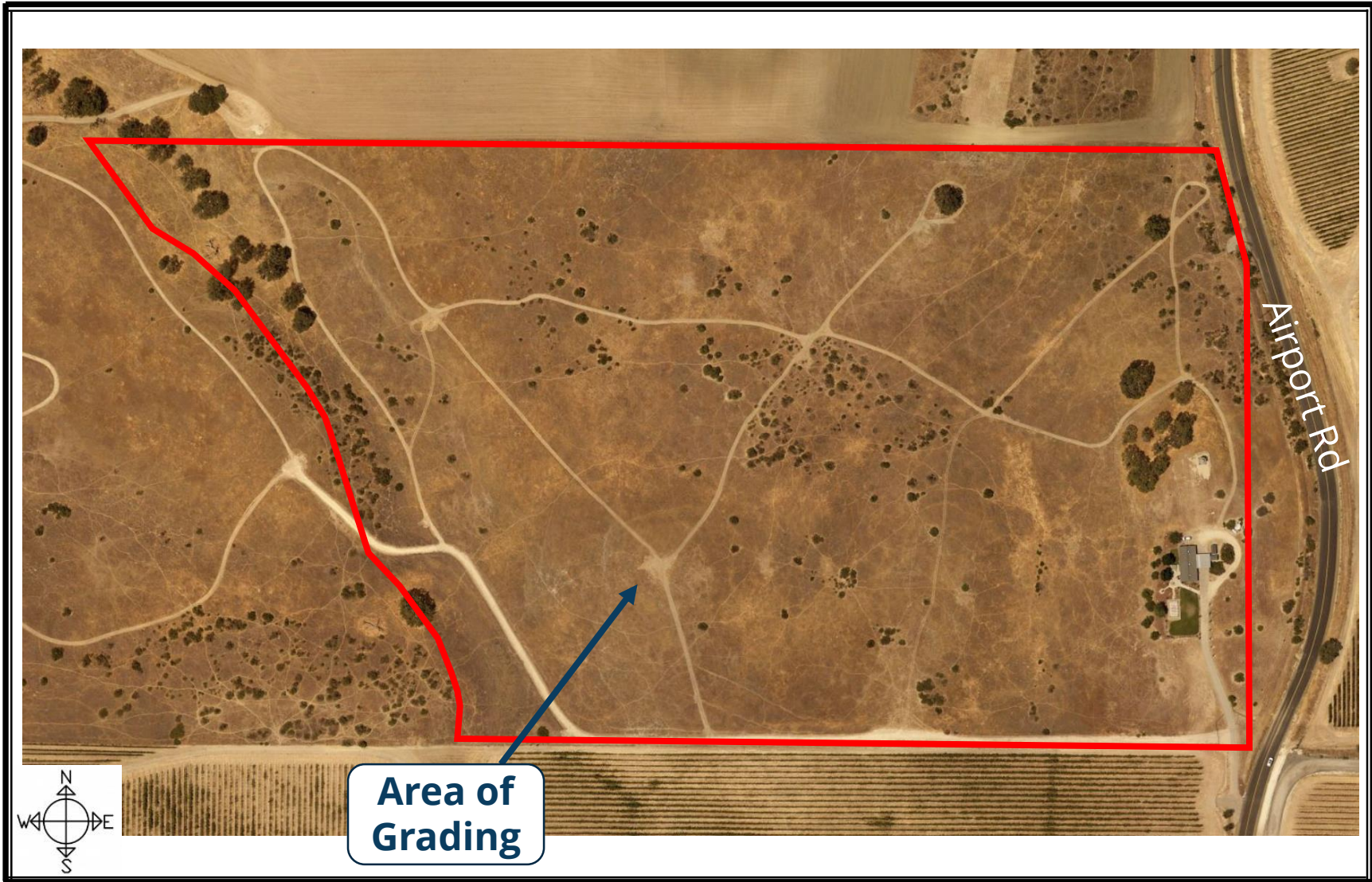

**Area of  
Grading**

Airport Rd



**COUNTY OF SAN LUIS OBISPO**

**Aerial  
PMTG2018-00084**



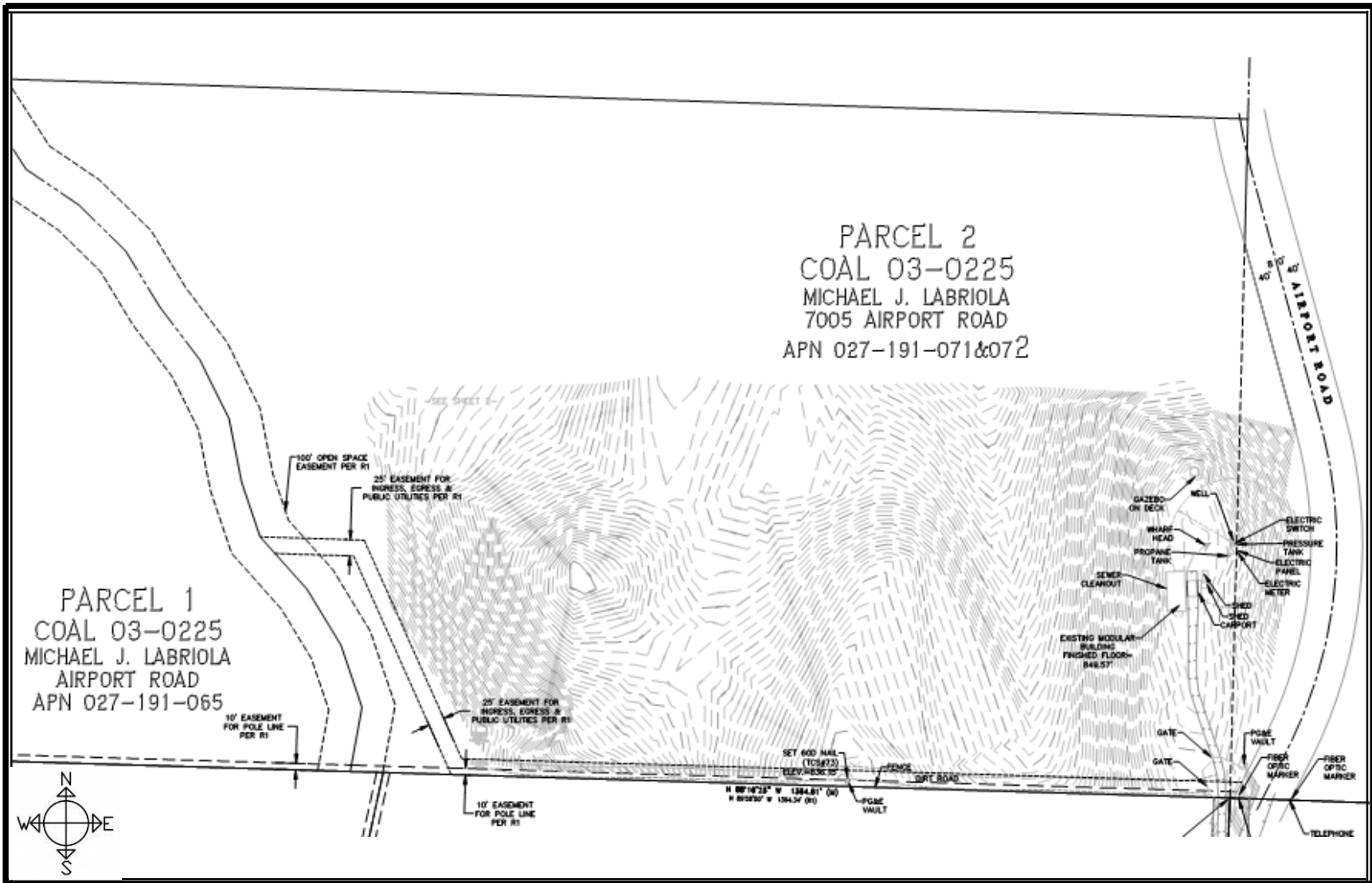

COUNTY OF SAN LUIS OBISPO

**Existing Site Map**  
**PMTG2018-00084**

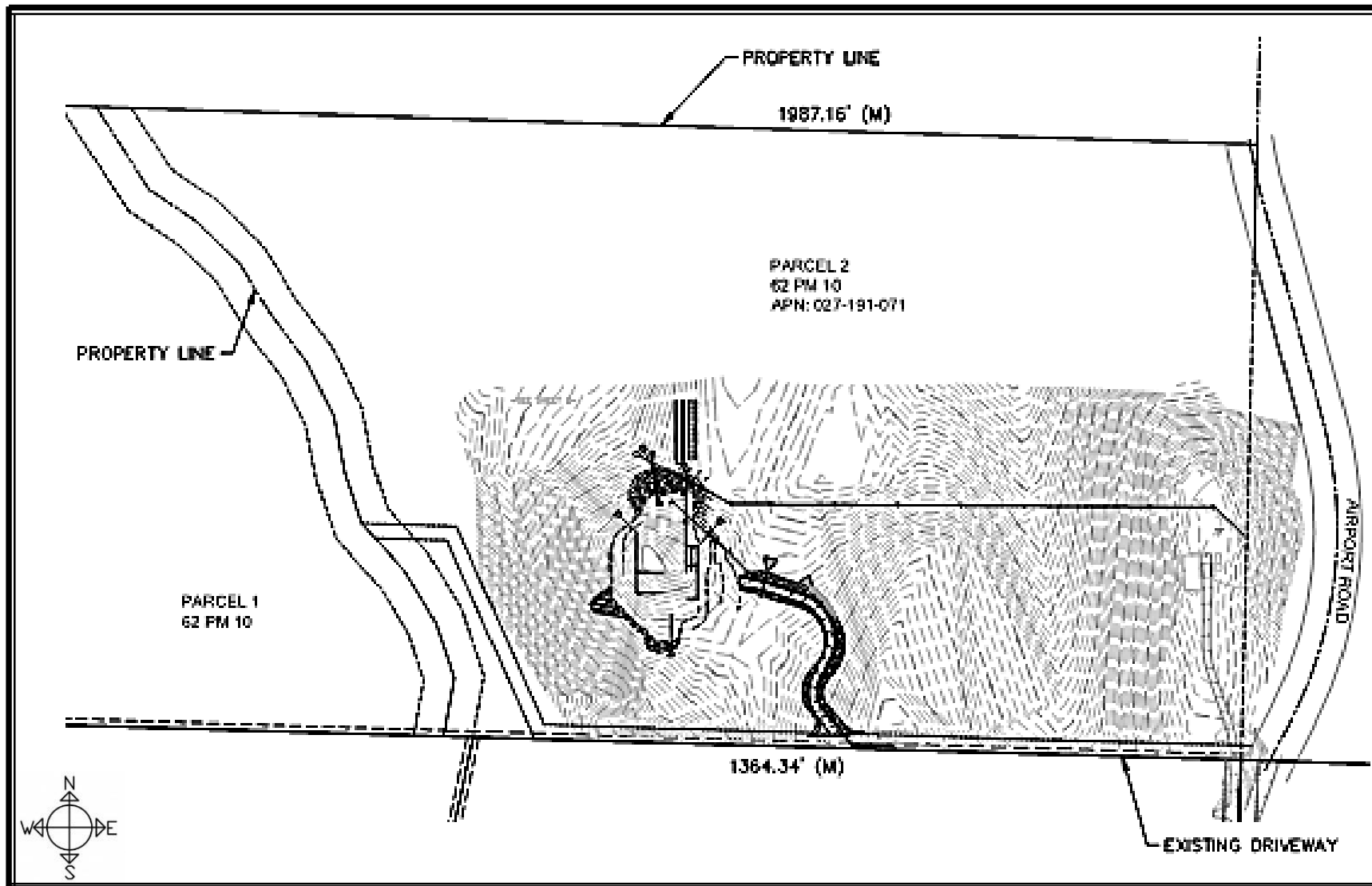

COUNTY OF SAN LUIS OBISPO

Proposed Site Map  
PMTG2018-00084

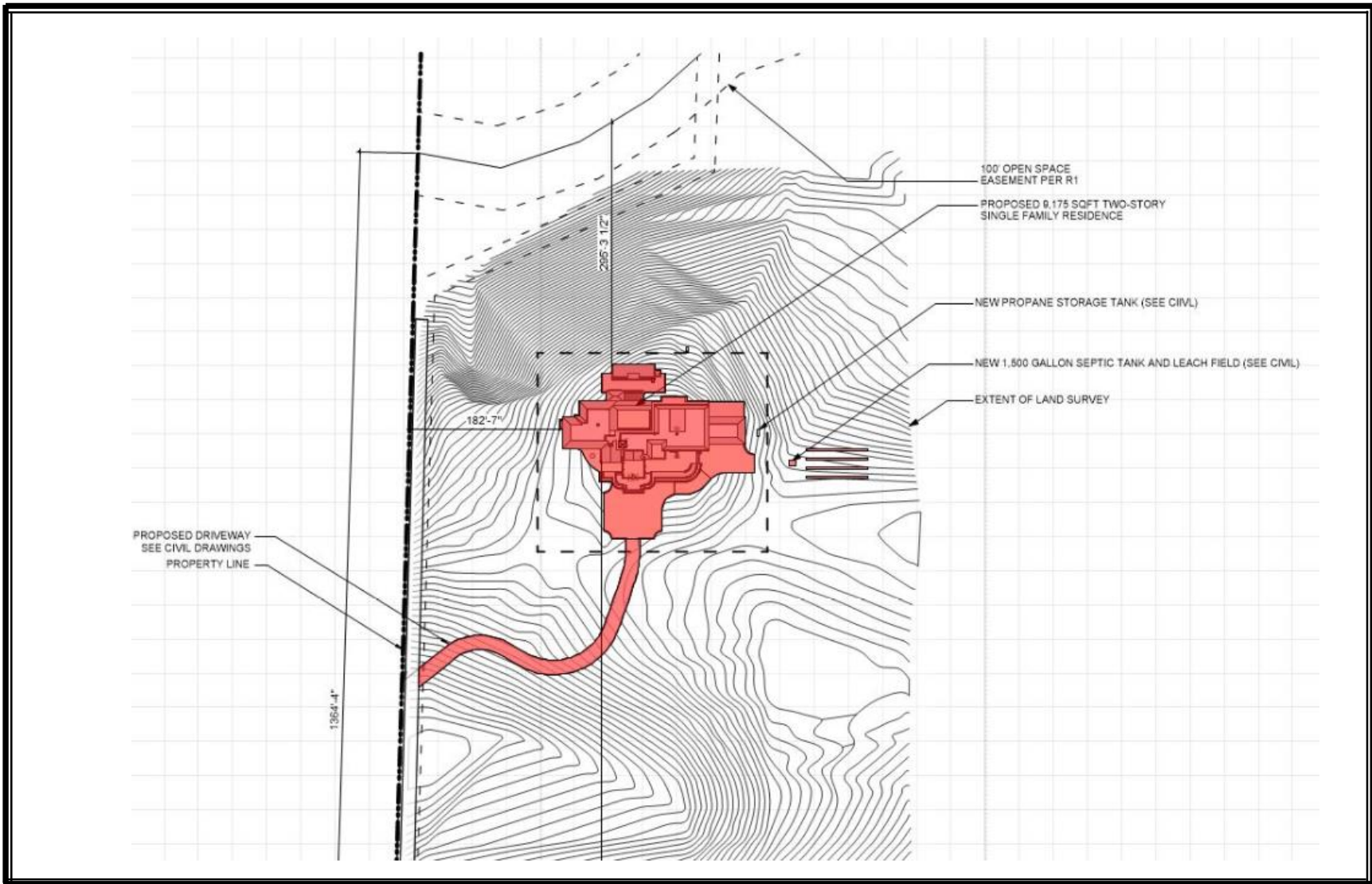

COUNTY OF SAN LUIS OBISPO

**Area of Disturbance  
PMTG2018-00084**

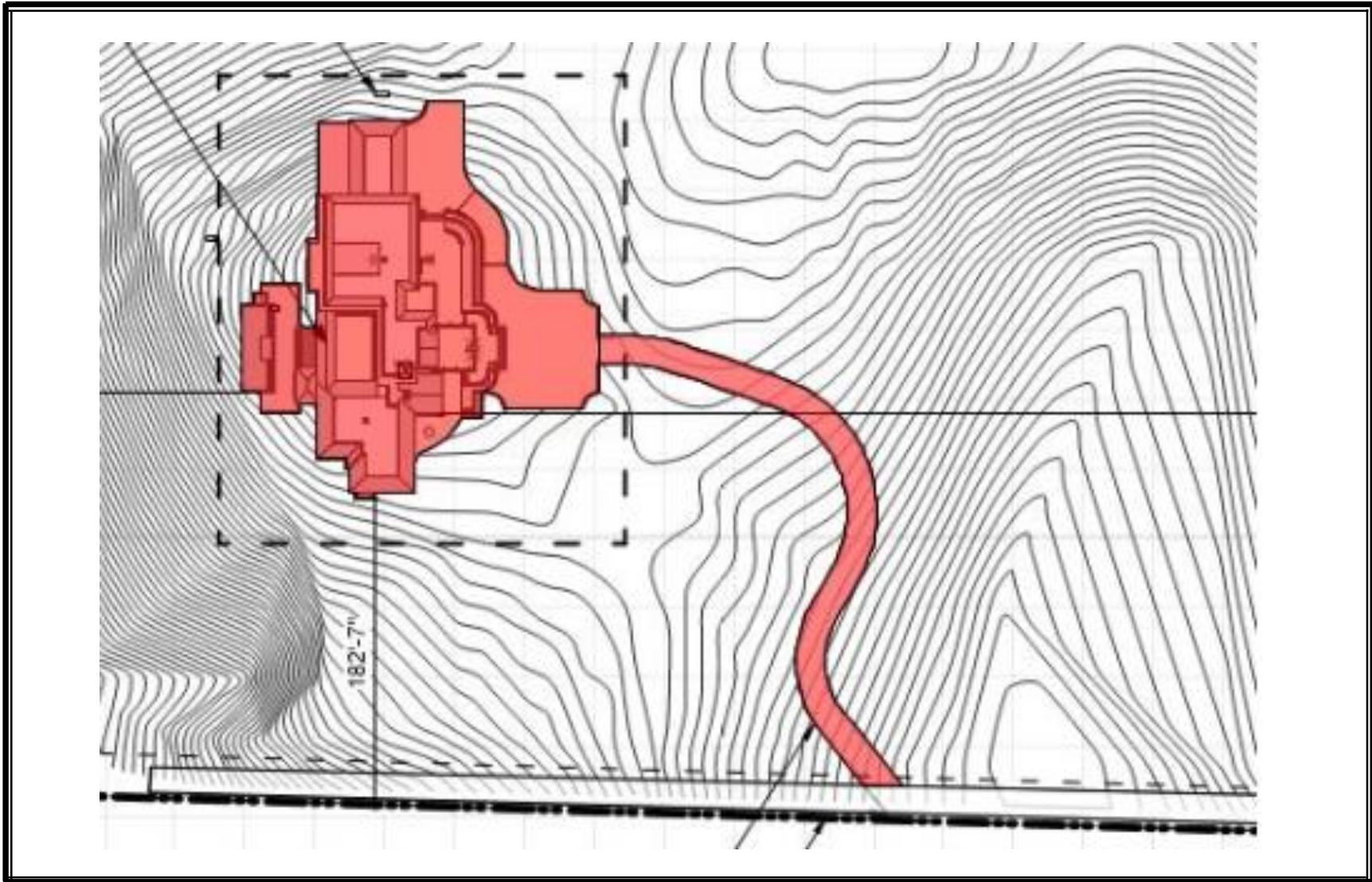

COUNTY OF SAN LUIS OBISPO

Area of Disturbance  
PMTG2018-00084



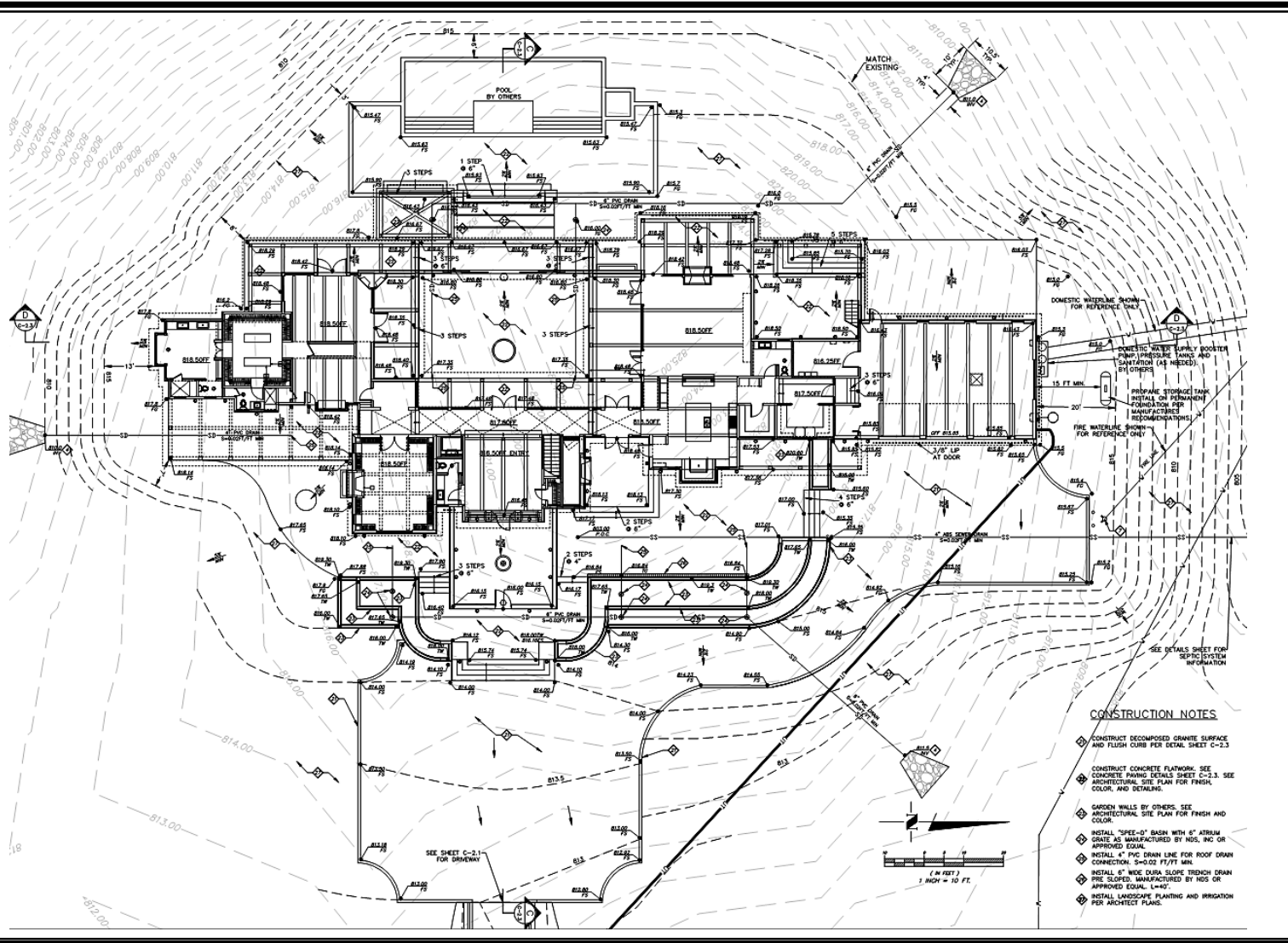

COUNTY  
OF SAN LUIS  
OBISPO

COUNTY OF SAN LUIS OBISPO

**Grading Plan**  
**PMTG2018-00084**

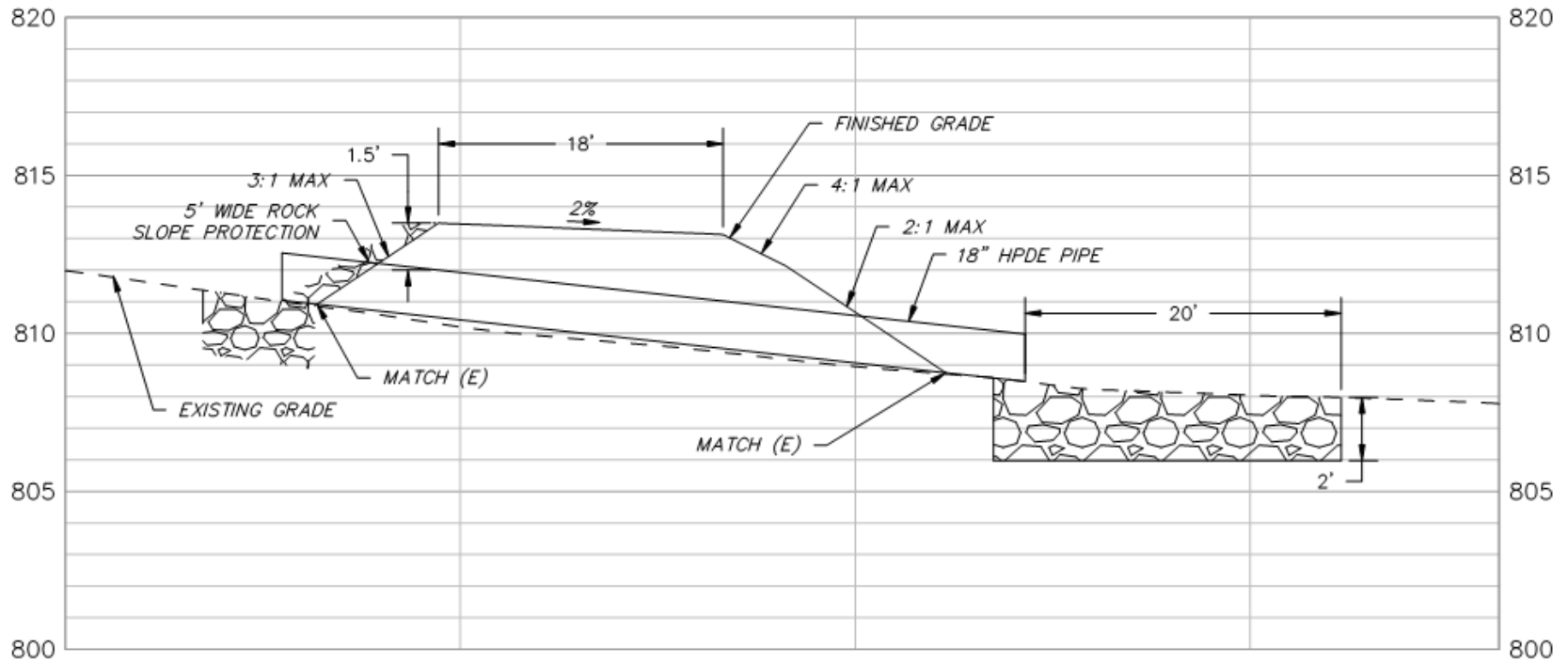

B-B

VERT. 1"=5'  
HORIZON. 1"=10'



COUNTY OF SAN LUIS OBISPO

Grading Sections  
PMTG2018-00084



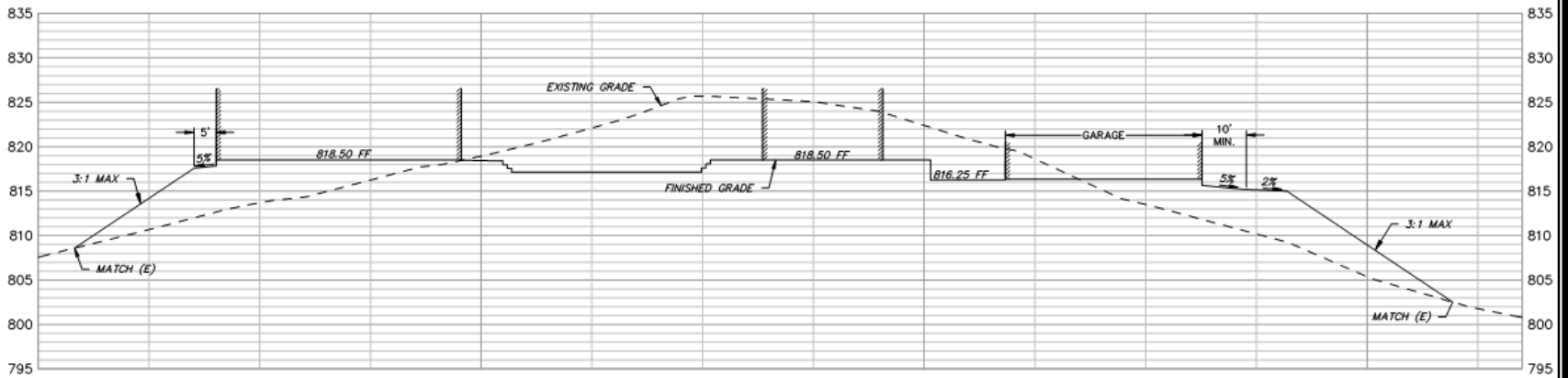

D-D  
 VERT. 1"=10'  
 HORIZON. 1"=20'



COUNTY OF SAN LUIS OBISPO

Grading Sections  
 PMTG2018-00084

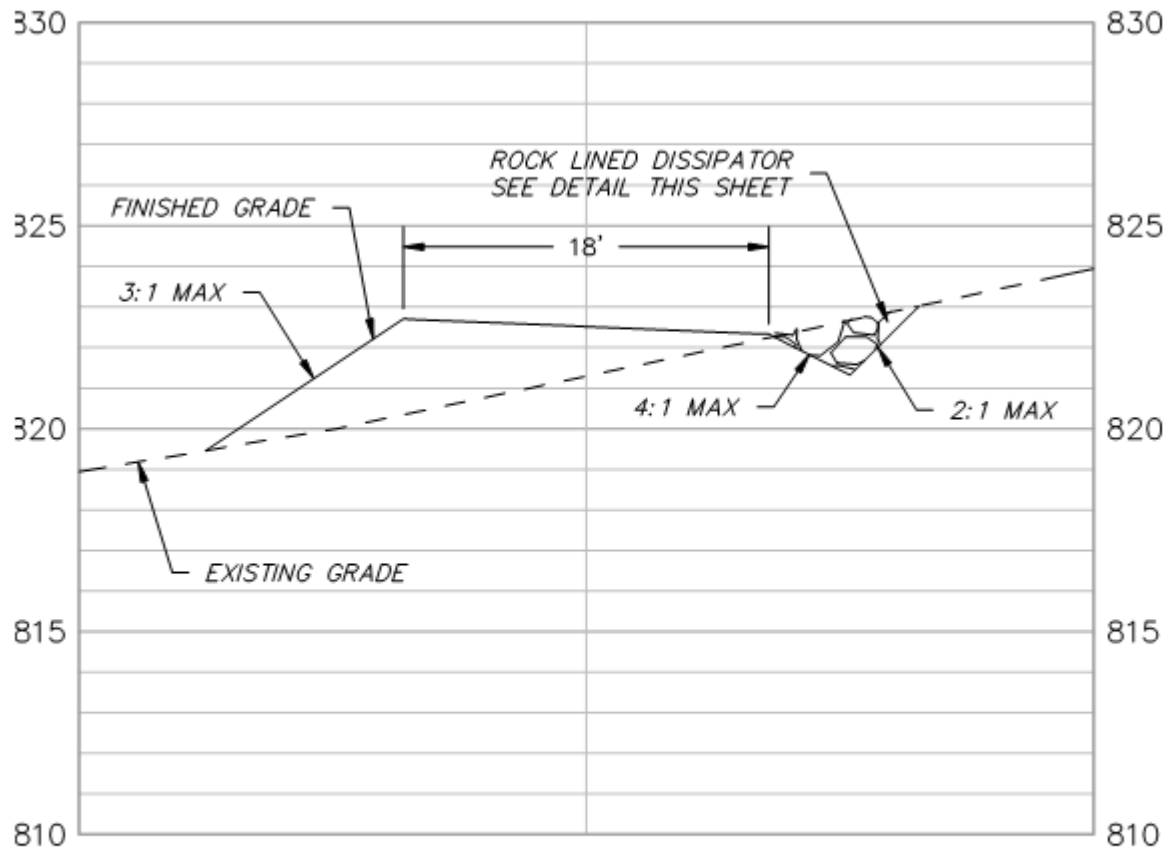

A-A

VERT. 1"=5'  
 HORIZON. 1"=10'



COUNTY OF SAN LUIS OBISPO

Grading Sections  
 PMTG2018-00084

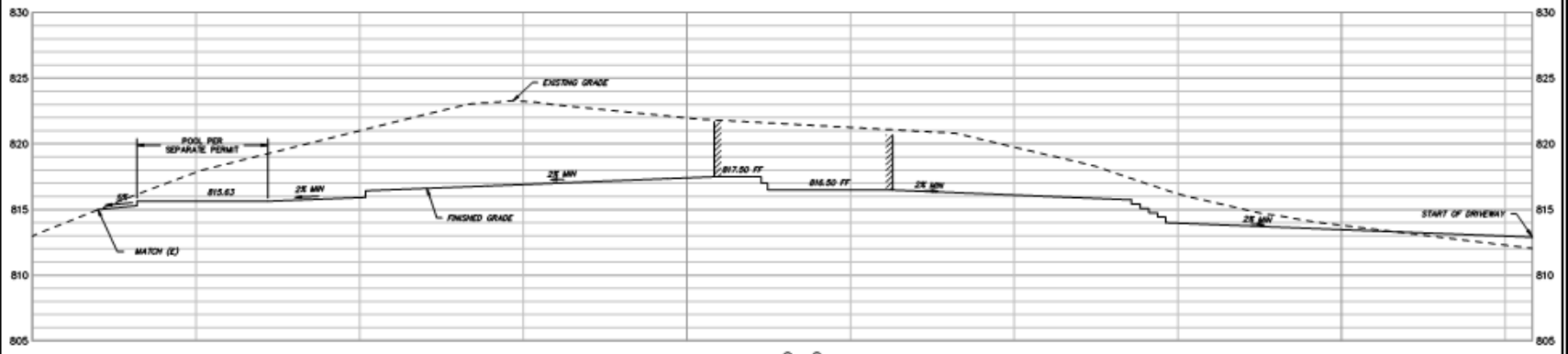

C-C  
 VERT. 1"=5'  
 HORIZON. 1"=10'



COUNTY OF SAN LUIS OBISPO

**Grading Sections  
 PMTG2018-00084**

Reply all | Delete Junk | ...

# [EXT]RE: NCTC, AB52 -- PMTG2018-00084 LABRIOLA, North County Referral, Major Grading Permit, San Miguel

**FC** Fred Collins <fcollins@northernchumash.org>  
Tue 4/16, 6:35 AM  
Katie Nall

Reply all |

PMTG2018-00084 Labriola

**ATTENTION:** This email originated from outside the County's network. Use caution when opening attachments or links.

Good morning Katie,

NCTC has no comments on the above referenced proposed project, thank you.

Fred Collins  
NCTC

**From:** Mail for PL\_Referrals Group [mailto:plreferrals@co.slo.ca.us]  
**Sent:** Friday, April 12, 2019 1:08 PM  
**To:** fcollins\_northernchumash.org  
**Cc:** Katie Nall  
**Subject:** NCTC, AB52 -- PMTG2018-00084 LABRIOLA, North County Referral, Major Grading Permit, San Miguel

**County of San Luis Obispo  
Department of Planning & Building**

**PMTG2018-00084 LABRIOLA, North County Referral, Major Grading Permit, San Miguel  
APN(s): 027-191-071**

[DIRECT LINK to Project Referral](#)

**PLEASE CONTACT:**  
Katie Nall (kinall@co.slo.ca.us)

**The deadline for consultation request is:  
May 13<sup>th</sup> 2019**

\*\*\*\*\*

The County of San Luis Obispo is notifying you of the proposed project listed above. The project application was recently filed with the Planning Department for review and approval. State law under Assembly Bill 52 (Public Resources Code Section 21080.3.1) allows California

 Reply all |   Delete Junk |  ...

attached letter is your official notification and provides target timelines for the AB 52 Consultation Process.

*If you have questions about this project or wish to request consultation, please contact the project manager(s) listed above and provide a designated lead contact person for this consultation*

*For general questions about the AB52 process, or as an additional point of contact for specific projects, inquiries can be directed to the AB 52 Coordinator, Schani Siong (805-781-4374 or [ssiong@co.slo.ca.us](mailto:ssiong@co.slo.ca.us)) or Hilary Brown (805-788-2009 or [hbrown@co.slo.ca.us](mailto:hbrown@co.slo.ca.us)).*

Getting too much email from Fred Collins <[fcollins@northernchumash.org](mailto:fcollins@northernchumash.org)>? [You can unsubscribe](#)